

Hypoxia-inducible factor signaling in pulmonary hypertension

Soni Savai Pullamsetti, ... , Werner Seeger, Rajkumar Savai

J Clin Invest. 2020. <https://doi.org/10.1172/JCI137558>.

Review [In-Press Preview](#)

Pulmonary hypertension (PH) is characterized by pulmonary artery remodeling that can subsequently culminate in right heart failure and premature death. Emerging evidence suggests that Hypoxia Inducible Factor (HIF) signaling plays a fundamental and pivotal role in the pathogenesis of PH. This review summarizes the regulation of HIF isoforms and their impact in various PH subtypes, as well as the elaborate conditional and cell specific knockout mouse studies that brought the role of this pathway to light. We also discuss the current preclinical status of pan- and isoform-selective HIF inhibitors, and propose new research areas that may facilitate HIF isoform-specific inhibition as a novel therapeutic strategy for PH and right heart failure.

Find the latest version:

<https://jci.me/137558/pdf>



Hypoxia-inducible factor signaling in pulmonary hypertension

Soni Savai Pullamsetti^{1,2}, Argen Mamazhakypov¹, Norbert Weissmann², Werner Seeger^{1,2},
Rajkumar Savai^{1,2}

¹Department of Lung Development and Remodeling, Max Planck Institute for Heart and Lung Research, member of the German Center for Lung Research (DZL), Member of the Cardio-Pulmonary Institute (CPI), Bad Nauheim, Germany

²Department of Internal Medicine, Universities of Giessen and Marburg Lung Center (UGMLC), member of the DZL and CPI, Justus Liebig University, Giessen, Germany

Correspondence: Soni Savai Pullamsetti

Max Planck Institute for Heart and Lung Research

Parkstraße 1 61231 Bad Nauheim

Email: soni.pullamsetti@mpi-bn.mpg.de

Abstract

Pulmonary hypertension (PH) is characterized by pulmonary artery remodeling that can subsequently culminate in right heart failure and premature death. Emerging evidence suggests that Hypoxia Inducible Factor (HIF) signaling plays a fundamental and pivotal role in the pathogenesis of PH. This review summarizes the regulation of HIF isoforms and their impact in various PH subtypes, as well as the elaborate conditional and cell specific knockout mouse studies that brought the role of this pathway to light. We also discuss the current preclinical status of pan- and isoform-selective HIF inhibitors, and propose new research areas that may facilitate HIF isoform-specific inhibition as a novel therapeutic strategy for PH and right heart failure.

Keywords: hypoxia-inducible factor, pulmonary hypertension, right ventricle

HIF signaling and biology

The transcription factor hypoxia-inducible factor (HIF) is a master regulator of oxygen homeostasis that acts as a heterodimeric complex composed of oxygen-sensitive α -subunit (HIF- α : including HIF-1 α , HIF-2 α (EPAS1), and HIF-3 α) and oxygen-insensitive β -subunit (HIF- β : including HIF-1 β (aryl hydrocarbon receptor nuclear translocator, ARNT1), ARNT2, and ARNT3) (1). In oxygenized cells, HIF- α subunit is inactivated via hydroxylation by prolyl hydroxylase domain proteins (PHDs) and factor inhibiting HIF (FIH), which allows the binding of von Hippel–Lindau (vHL) tumor suppressor protein, a component of an E3 ubiquitin ligase complex that subsequently targets hydroxylated HIF- α for proteasomal degradation. Under hypoxic conditions, oxygen becomes limited, leading to the attenuation of HIF- α hydroxylation and resulting in stabilization of HIF- α subunits. This initiates nuclear translocation and binding of HIF- α subunit with HIF- β subunit, where this activated HIF initiates adaptive response to hypoxia by inducing or repressing broad range of genes involved in regulation of vascular tone, angiogenesis, erythropoiesis, cellular metabolism, proliferation, survival, and autophagic response (1). However, non-hypoxic conditions i.e. growth factors, hormones, or cytokines also modulate HIF- α subunits at various levels (gene transcription, mRNA processing, protein–protein interactions, and post-translational modifications (detailed description found in reviews (1, 2)) and regulate plethora of signaling pathways. In lung, HIFs orchestrate physiological response to hypoxia and contribute to the pathogenesis of numerous disorders, including lung cancer, chronic obstructive pulmonary disease (COPD), pulmonary fibrosis (PF), and pulmonary hypertension (PH).

Regulation of HIF signaling pathways in PH patients

Pulmonary hypertension (PH) is a severe pulmonary vascular disorder characterized by excessive proliferation of vascular cells, increased extracellular matrix (ECM) deposition, and accumulation of inflammatory cells within the pulmonary vascular wall, collectively resulting in increased pulmonary vascular resistance (3). Despite extensive research in this field, the mechanisms underlying disease development and progression are incompletely understood (4). Among many dysregulated signaling pathways, HIF signaling has been identified as one underlying mechanism determining disease progression not only in pulmonary arterial hypertension (PAH, Group 1 PH),

but also in PH due to lung diseases and/or hypoxia, including PH associated with chronic high altitude exposure (5, 6), COPD (7), and PF (8) (Group III PH). Notably, augmented expression of HIF-1 α has been observed in lung tissues of patients with PAH (9-13), chronic thromboembolic PH (14) and idiopathic PF-associated PH (15, 16). While, HIF-2 α has been associated with congenital diaphragmatic hernia-associated PH (17). In addition, neonatal patients with acute respiratory disease-associated PH also display increased circulating levels of HIF-1 α (18). Moreover, HIF-1 α and its target genes vascular endothelial growth factor (*VEGF*) and erythropoietin (*EPO*) are upregulated in peripheral blood cells of newborns with cyanosis and persistent PH, therefore representing early markers of generalized hypoxia (19). Similarly, increases in circulating bone-marrow derived progenitor cells observed in PAH patients are regulated by HIF-1 α -driven C-X-C motif chemokine 12 (*CXCL12*) expression in pulmonary artery endothelial cells (PAECs) (20). The cellular sources of increased HIF-1 α expression in lung tissue of PH patients are PAECs (16, 21) and smooth muscle cells (PASMCs) (22, 23). While some reports show HIF-1 α upregulation in the pulmonary arteries of PAH patients (24), others provide evidence of decreased HIF-1 α in PASMCs isolated from idiopathic PAH (IPAH) patients (25, 26). PAH patients also display increased pulmonary expression of HIF-1 β (11) and similarly, the expression of HIF-2 α has been found to be increased in pulmonary arteries of patients with PAH (27) (24) and IPF-associated PH (16). The cellular sources of increased HIF-2 α expression in the lung tissue of PH patients are mainly PAECs (16, 27, 28), suggesting cell-type and context-specific regulation of HIF isoforms in PH.

Upstream regulators of the HIF system in PH

Activation of HIFs in various subtypes of PH suggest that along with chronic hypoxia, other factors responsible for the initiation of PH (gene variants, vasoconstriction, endothelial dysfunction, mitochondrial abnormalities, dysregulated cell growth, and inflammation) can activate HIF signaling pathways to trigger alterations in pulmonary vascular cells, inflammatory cells and cardiac cells that remodel lung vasculature and right ventricle (RV) (Figure 1).

Gene variants of HIF pathway: Gene variants of HIF pathway molecules identified in high-altitude populations and in patients with Chuvash polycythemia illustrate the HIF pathway's importance in pulmonary vascular adaptation and remodeling. Chuvash polycythemia is characterized by the

presence of the R200W (598C>T) missense mutation in vHL, which reduces its binding to hydroxylated HIF- α subunits and thus increases HIF-1 α and HIF-2 α levels (29). This leads to expression of HIF target genes including *EPO* and *VEGF* and results in development of polycythemia. In Chuvash polycythemia, apart from erythrocytosis, several vHL loss-of-function mutations including D126N (376G>A) (30), D126N (376G>A)/S183L (548C>T) (31), and M54I (162G>C) were found associated with higher resting pulmonary artery pressure (PAP), severe PH, and RV dysfunction (32) (33-35). Moreover, mutation in HIF-2 α , G537R which impairs HIF-2 α hydroxylation, causing familial erythrocytosis, is also associated with PH (36).

Several genome-wide selection studies (GWSS) have been performed on high-altitude populations including Tibetans, Ethiopians, and Andeans (5, 6) and identified signals of positive selection for gene variants in and around the HIF pathway enabling these populations to adapt to life at high-altitude hypoxia. However, long-term high-altitude residency may lead to a sustained increase in PAP and development of PH. Among all high-altitude populations, Tibetans have the lowest PAP (37). A candidate gene study based on the results of genome-wide analyses that identified gene variants associated with high-altitude adaptation found that *EPAS1* (HIF-2 α) variants are associated with lower PAP in Tibetans (38). Furthermore, Tibetans who live at low altitudes but harbor gene variants in *EPAS1* (encoding HIF-2 α) and *EGLN1* (encoding PHD2) display blunted hypoxic pulmonary vasoconstriction (39). Thus, future studies are required to delineate the role of HIF pathway gene variants in driving high-altitude PH susceptibility or resistance among indigenous high-altitude populations.

Vasomodulatory factors: Various vasomodulatory factors are shown to regulate HIF isoform stability and transcriptional activity in PAECs (Figure 2, Table 1). Nitric oxide (NO) maintains pulmonary vascular tone, and its downregulation is implicated in PH pathogenesis. Recent studies indicate that the NO plays a central role in hypoxia/HIF axis regulation. For example, in PAECs, hypoxia leads to post-transcriptional negative regulation of endothelial NO synthase (eNOS) expression by the cis-natural antisense RNA sONE (40), which results in lower levels of NO and increased HIF-1 α stability. Accordingly, low levels of NO due to eNOS deletion also cause HIF-1 α stabilization and migration of normoxic endothelial cells (41). Moreover, endogenous regulators of NO production such as arginase-2 and asymmetric dimethyl arginine affect cell proliferation and inflammatory gene expression by stabilizing HIF-1 α in PAECs (42). ET-1, a

potent vasoconstrictor, also stabilizes HIF-1 α , which in turn promotes the HIF-1 α -induced glycolytic switch via eNOS-mediated reactive oxygen species (ROS) production in PAECs (43). Likewise, stimulation of normoxic PSMCs with ET-1 increases stability of HIF-1 α as a result of increased Ca²⁺ and ROS and increases transcriptional activity of HIF-1 α due to ERK1/2 pathway activation, which phosphorylates p300 to increase its binding to HIF-1 α (44). Moreover, ET-1 promotes HIF-1 α protein stabilization in normoxic PSMCs via calcineurin-dependent RACK1 dephosphorylation, which in turn inhibits PHD2 activity (45). Importantly, HIF also shown to regulate ET-1 synthesis. Mice with global deficiency for NEPAS, a transcript variant of HIF-3 α , exhibit *ET-1* overexpression, which leads to pulmonary vascular remodeling and dilated cardiomyopathy due to excessive tissue vascularization that is evident from birth and progresses in later stages of life (46). Thus, HIF and ET-1 form a bidirectional regulatory loop that plays an important role in driving pulmonary vascular remodeling.

Inflammation, growth factors and microRNAs: Hypoxia induces upregulation of IL-33 and its receptor ST2 in PAECs, which activates downstream HIF-1 α /VEGF signaling resulting in enhanced proliferation, adhesion, and angiogenesis in an ST2-dependent fashion (47). Similarly, hormones and growth factors such as bone morphogenic protein (BMP), placental growth factor (PIGF), platelet-derived growth factor (PDGF), EPO, estradiol, and signaling molecules regulate HIF isoform transcriptional activity in PAECs. For example, in patients with sickle cell disease (SCD)-associated PH, elevated levels of PIGF result in downregulation of miR-199a2, a negative regulator of HIF-1 α . Furthermore, peroxisome proliferator-activated receptor- α (PPAR α) agonist-mediated transcription of miR-199a2 attenuates *ET-1* expression and HIF-1 α level, ameliorating PH in a mouse model of SCD (48-50). Estradiol negatively regulates *ET-1* expression in PAECs by interfering with HIF activity, possibly through competition for limiting quantities of CBP/p300 (51). Estradiol also negatively regulates HIF-2 α by promoting its degradation by estrogen receptor β (ER β)-mediated PHD2 upregulation in hypoxic PAECs (52). By contrast, the BMP signaling molecules SMAD1/5 transcriptionally activate atonal BHLH transcription factor 8 (*ATOH8*) expression, which interacts with HIF-2 α to reduce its abundance and expression of its target genes delta-like protein 4 (*DLL4*) and Angiopoietin-2 (*ANGPT2*) in hypoxia-exposed PAECs (53). *ATOH8* KO mice spontaneously develop PH, suggesting an important role for BMP signaling in regulating the HIF pathway. Moreover, HIF-1 α -driven expression of miR-322/424 in human

endothelial cells (ECs) attenuates HIF-1 α degradation by causing post-transcriptional repression of cullin-1, an E3 ubiquitin ligase scaffolding protein (54).

However, with regard to PASMCs, cross-regulation between the adhesion molecule CD146 and HIF-1 α via the NF- κ B pathway in PASMCs has been shown to trigger pulmonary vascular remodeling. Disruption of the CD146/HIF-1 α axis in PASMC blunts vascular remodeling and produces a marked attenuation of PH (55). Furthermore, exaggerated proliferation in PASMCs exposed to growth factors such as epidermal growth factor (EGF), fibroblast growth factor (FGF2), PDGF, or is mediated by HIF-1 α but not HIF-2 α activation (56), suggesting that HIF-1 α acts downstream of these growth factors, which are well-established as disease-driving factors in PH. PPAR γ agonists exert anti-proliferative effects on PASMCs via PPAR γ -mediated inhibition of HIF-1 α and its downstream genes like *PDK-1*, *TRCP1*, and *TRCP6* (57, 58). However, hypoxia induces PPAR γ downregulation via HIF-1 α in PASMCs (57, 58), suggesting a negative feedback loop mechanism between PPAR γ and HIF-1 α . Among other regulators, hypoxia-induced downregulation of miR-206 (59) and miR-150 (60) promotes a pro-proliferative and pro-migratory phenotype of PASMCs by targeting HIF-1 α . Furthermore, in rat PASMCs, upregulation of molecules related to both SUMOylation (SUMO-1) and deSUMOylation (SENP-1) leads to increased HIF-1 α stability and transcriptional activity, thus increasing proliferation (61, 62).

Mitochondrial abnormalities: The interplay between mitochondrial abnormalities, NADPH oxidases (NOX) and ROS has been established as an important activator of HIF-1 α in pulmonary vascular cells in PH (63-65). For example, mitochondrial abnormalities that shift metabolism away from oxidative phosphorylation toward glycolysis (notably pyruvate dehydrogenase kinase (PDK) activation) lead to a normoxic impairment of electron flux and reduced mitochondrial ROS production (66). This pseudo-hypoxic signal is associated with nuclear translocation of HIF-1 α . On the contrary, reports suggest that low levels of superoxide dismutase 2 (SOD2), as observed in PAECs from patients with IPAH, promotes HIF-1 α stabilization due to increased ROS levels (21). Mechanical stretch imposed on PASMCs due to pulmonary hemodynamic stress causes mitochondrial complex-III-mediated ROS formation, which both induces the NF- κ B pathway and inhibits Phd2, leading to HIF-1 α activation (67), indicating that hemodynamic stress itself serves as an independent regulator of HIF-1 α . Indeed, several molecules that are upstream regulators of ROS are implicated in HIF-1 α activation. For instance, loss of Sirtuin3, a crucial regulator of

mitochondrial function in PASMCs, causes mitochondrial dysfunction leading to ROS production and HIF-1 α stabilization (68). As a consequence, sirtuin3 KO mice develop spontaneous PH and RV hypertrophy (68). Recently, we identified a molecular mechanism in which a scaffold protein, Ras association domain family 1A (RASSF1A), acts as a crucial regulator of HIF-1 α signaling in PASMCs. Upon hypoxia, HIF-1 α upregulates *RASSF1A* expression, and RASSF1A is stabilized by ROS-driven and protein kinase C (PKC)-mediated phosphorylation. RASSF1A in turn stabilizes HIF-1 α , leading to increased HIF-1 transcriptional activity (69). This crucial RASSF1A-HIF-1 α feed-forward loop determines pro-proliferative and glycolytic switch of PASMCs and pulmonary artery adventitial fibroblasts (PAAFs) (69). Disruption of RASSF1A/HIF-1 α cross-talk by genetic ablation of RASSF1A mitigates pulmonary vascular remodeling in mice exposed to chronic hypoxia.

HIFs' role in PH-associated cellular and molecular abnormalities

Under extended exposure to reduced oxygen levels in pulmonary vascular cells, HIF isoforms transcriptionally activate a series of genes (Figure 2 and 3) that regulate vascular tone, angiogenesis, metabolism, and proliferation. Moreover, recent studies highlighted the potential role of HIFs and the underlying molecular mechanisms in the dysregulation of the innate and adaptive immune system in PH.

PAECs: PAECs exhibit different phenotypes (proliferative, migratory, angiogenic, and/or endothelial to mesenchymal transition (EndoMT)) during PH pathogenesis, and HIF isoforms play a decisive role in defining these phenotypes. For example, HIF-1 induces Cyclin-dependent kinase inhibitor 1B (*p27^{Kip1}*) upregulation and cyclin D1 downregulation, leading to decreased proliferation and migration of hypoxic PAECs (70). By contrast, HIF-2-driven octamer-binding transcription factor 4 (OCT4) expression via miR-130/131-mediated downregulation of PPAR γ -apelin signaling results in increased proliferation of PAECs (71). In addition, both HIF-1 and HIF-2 in PAECs contributes to altered metabolic phenotype by modulating the expression of distinct mitochondrial enzymes such as pyruvate dehydrogenase kinase 1 (*PDK1*), hexokinase 1,2 (*HK1,2*); lactate dehydrogenase-A (*LDHA*), glucose transporter-1,3 (*GLUT1,3*) to regulate anaerobic glycolysis and warburg effect (aerobic glycolysis). The influence of HIF-1 on glycolytic metabolism is well established (72); the Warburg effect in IPAH could possibly be driven by HIF-

1 α stabilization, independently of the hypoxic environment. On the other hand, HIF-2, but not HIF-1, by upregulating SNAIL transcription factors triggers EndoMT, a mechanism potentially involved in the development of occlusive intimal/neointimal lesions and severe pulmonary vascular wall thickening in IPAH (73). Furthermore, EC HIF-2 influences the development of hypoxic PH via an arginase-1–dependent mechanism. The HIF-2:arginase-1 axis dysregulates vascular NO homeostasis (74, 75), resulting in PH in hypoxia-exposed mice (74). Consequently, EC arginase-1 loss attenuates PH in hypoxia-exposed mice (74), and arginase inhibition prevents PH in monocrotaline (MCT)-injected rats (76). Although expression of HIF-2-mediated angiopoietin-1 and -2 in ECs is essential to maintain proper pulmonary vascular homeostasis (77, 78). These data propose that HIF-1 and HIF-2 exert pathogenic roles in PH by regulating distinct cellular processes in PAECs.

PASMCs: In PASMCs, HIF isoforms not only regulate genes related to cell proliferation and synthetic phenotypes but also genes related to vasoconstriction (Ca²⁺ modulation/ion channels), oxidative stress, mitochondrial fragmentation, and the renin-angiotensin-aldosterone system (RAAS) (Figure 3). Increased PASMC proliferation and the pro-synthetic phenotypic switch observed in hypoxia is mediated by HIF-1-driven expression of miR-9-1 and miR-9-3, which negatively regulate myocardin (*MYOCD*) expression (79). Augmented proliferation of rat PASMCs is associated with inhibition of the BMP pathway as a result of HIF-1-induced, but not HIF-2-induced, miR-322, which causes post-translational repression of *Bmpr1a* and *Smad5* genes (80). HIF-1-dependent upregulation of miR-210 causes apoptosis resistance in PASMCs by targeting transcription factor E2F3 (81). By contrast, HIF-2 promotes hypoxia-responsive PASMC migration and contractility by upregulating thrombospondin-1 (82). Thus, multiple mechanisms contribute to the pro-proliferative, pro-migratory, and apoptosis resistance phenotypes of PASMCs. Furthermore, hypoxia-induced muscularization of non-muscularized pulmonary arterioles involves preexisting smooth muscle cell (SMC) progenitor cells that undergo dedifferentiation, migration to the distal vessel, proliferation, and redifferentiation (83). Elegant studies from Sheikh et al. demonstrated that activation of these progenitor cells starts with HIF-1 α -mediated PDGF- β expression (84), and progresses with expansion of these progenitor-derived SMCs via HIF-1 α -mediated Krüppel-like factor 4 (*KLF4*) expression (85). These studies

demonstrate a central role of HIF-1 in the initiation as well as progression of pulmonary artery muscularization in hypoxia-induced PH.

Changes in intracellular K^+ and Ca^{2+} play a pivotal role in the regulation of contraction, migration, and proliferation of PASMCs (2). Notably, HIF-1 plays an essential role in modulating $[Ca^{2+}]_i$ levels in PASMCs by regulating the expression of various ion channels. HIF-1 promotes overexpression of transient receptor potential (TRPC) channel members, *TRPC1* and *TRPC6*, and subsequently increases intracellular Ca^{2+} concentration ($[Ca^{2+}]_i$) in hypoxic PASMCs (86). In addition, HIF-1 via *ET-1* and subsequently repressing voltage gated K^+ channels members also increases $[Ca^{2+}]_i$ (87). On the other hand, HIF-1 activates expression of the $\beta 1$ -subunit (*KCNMB1*) of the calcium-sensitive K^+ channel BKCa, which prevents excessive rise in $[Ca^{2+}]_i$ in PASMCs (88).

PAAFs: Although both HIF-1 α and HIF-2 α are activated in PAAFs in response to hypoxia, HIF-2 α induction appears to play the dominant role in the proliferation response, whereas both HIF-1 and HIF-2 increase PAAF migration to a similar extent (89). Furthermore, studies suggest that HIF-1 via the regulation of *ACE* and *ACE2* (homolog of ACE that counterbalances the function of ACE) directly participates in the regulation of the RAAS system and consequently PAAF proliferation (90) (91) (92).

Inflammatory cells: Immune cells play an essential role in pulmonary vascular remodeling by regulating the functions of pulmonary vascular cells (93). For example, hypoxic PAAFs drive pro-fibrotic macrophage phenotypes under the control of HIF-1, resulting in the release of various paracrine factors. Importantly, macrophage-produced VEGF and IL-6 are shown to promote pulmonary vascular remodeling (12).

The role of HIF system in pulmonary vascular remodeling

Considering the multitude of cellular and mechanistic roles of HIF pathway, it is not surprising that knockout mouse models of HIF pathway (*Hif-1/2 α* , *vHL*, and *Phd2*) provided valuable insights on the HIF pathway in the hypoxic adaptation of the pulmonary vasculature and the development of PH. Earlier studies revealed that the genes of the HIF pathway are crucial for embryonic

development and that biallelic deletion of the majority of those genes is lethal. For example, homozygous deletion of *Phd2* in mice leads to embryonic lethality, although *Phd1/3* double knockout leads to viable and fertile mice (94). Complete deletion of *Hif1a* (95), *Hif2a* (96), and *Hif1b* (97) in mice all result in embryonic lethality due to various developmental defects. In contrast, mice with global heterozygous deletion of either *Hif1a* or *Hif2a* reach adulthood and do not display phenotypes in homeostatic conditions, making them useful to study the role of HIFs in disease. For example, mice with heterozygous deletion of *Hif1a* exhibit attenuated PH and RV hypertrophy upon hypoxia exposure (98). By contrast, mice with heterozygous deletion of *Hif2a* are completely protected from hypoxia-induced PH (99). Further to evaluate how global deletion of HIF isoforms during adult life affects hypoxia-induced PH, Hu et al. showed that global *Hif1a* deletion in mice did not prevent hypoxia-induced PH, whereas mice with global *Hif2a* deletion did not survive long-term hypoxia (100). Conversely, global partial *Hif2a* deletion diminishes development of hypoxia-induced PH at 5 weeks in adult mice (100).

Furthermore, to tease out the cell- and postnatal- specific role of HIF pathway components in PH pathogenesis, various studies have used constitutive or inducible cell-specific knockout mouse models. For example, Ball et al. reported that SMC-specific postnatal (inducible) deletion of *Hif1a* attenuated PH but did not affect RV hypertrophy (101). Meanwhile, another study showed that mice with constitutive SMC-specific *Hif1a* deletion exacerbated hypoxia-induced PH (102). More recent studies demonstrated that mice with constitutive EC-specific *Hif1a* deletion are not protected from hypoxia-induced PH and RV hypertrophy (28, 74). However, in another study, mice with inducible EC *Hif1a* deletion were protected from PH and RV hypertrophy under hypoxia (85). Interestingly, inducible *Hif1a* deletion in either ECs and SMCs did not prevent hypoxia-induced PH and RV hypertrophy (103). In contrast, SMC progenitor (PDGFR- β^+)-specific postnatal deletion completely prevents PH and RV hypertrophy in hypoxia-exposed mice (104). With regard to HIF-2 α , Skuli et al. reported that mice with EC-specific *Hif2a* deletion develop PH and RV dilatation (but not RV hypertrophy) due to vascular leakage into the lung parenchyma (105). Similarly, Tang et al. demonstrated that EC-specific deletion of *Hif2a*, but not *Hif1a*, prevents mice from developing PH under hypoxic conditions (28). Interestingly, simultaneous deletion of *Hif1a* and *Hif2a* in ECs also provides protection against bleomycin-induced PH and RV hypertrophy despite lung fibrosis development (106). This data suggests prominent role of

Hif2a in ECs is critical in the initiation and progression of PH. However, results of EC-specific gene-deletion mouse models should be interpreted cautiously as depending on whether Cre or Cre/ERT2 system was used, gene deletion may be exclusively EC-specific or may other cell types also may be targeted, respectively (107).

Notably, multiple groups have shown that mice with *Phd2* deletion in ECs spontaneously develop severe PH associated with massive pulmonary vascular lesions and adverse RV remodeling that is evident from the age of 1.5 months (108-110). Concomitant deletion of both *Phd2* and *Hif1a* or *Phd2* and *Hif2a* in ECs identified HIF-2 α activation as a critical downstream modulator of PHD2 deficiency in PH development (108, 109). Interestingly, these mice show increased mortality within 6–9 months of age, presumably due to progressive RV failure (108, 109). Supporting this role of HIF-2 α activity in the effect of PHD2 deficiency, mice with both heterozygous and homozygous *Hif2a* G536W gain-of-function mutations develop spontaneous PH and RV hypertrophy without RV dilation (111). Furthermore, mice bearing homozygous knock-in of a human R200W vHL mutation (as found in patients with Chuvash polycythemia) develop PH (112). Notably, development of PH in this model is attenuated in the setting of heterozygous deletion of *Hif2a*, but not of *Hif1a* (112), suggesting a prominent role of HIF-2 α in vHL loss-of-function induced PH.

Furthermore, exploring the inflammatory- and immune- specific roles of HIF isoforms in the pathogenesis of PH, mice with EC-specific deletion of *Phd2* develop spontaneous PH due to *Hif2a* stabilization, which is partially attenuated by transplantation with wildtype bone marrow-derived cells, suggesting that HIF-2 activation in bone marrow-derived cells contribute to pulmonary vascular remodeling (113). In addition, mice with *Hif1a* deletion in myeloid cells are partially protected from hypoxia-induced PH and RV hypertrophy, mainly due to attenuated macrophage activity (114). Similarly, mice with monocyte-specific *Hif1a* deletion display attenuated PH, PA remodeling, and RV hypertrophy in response to hypoxia or hypoxia+sugen (SuHx) exposure (115). In addition to myeloid cells, HIF pathway is also involved in the regulation of lymphoid cells. For examples, *Phd2* deletion-induced *Hif2a* activation causes immune regulatory dysfunction (116), which may partially explain reduced regulatory T cell function associated PH development (117). Collectively, these studies suggest that both bone marrow-derived macrophages and thymus-

derived T cells are involved in pulmonary vascular remodeling at least in part due to HIF pathway activation.

Taken together global, inducible and cell -specific deletion of HIF isoforms and the HIF pathway molecules provided cell type- and context- specific roles of HIF isoforms in early as well as late stages of PH development in adult mice.

The role of HIF system in RV remodeling

RV failure is one of the most common causes of morbidity and mortality in PAH (118). Upon PH onset, the RV undergoes remodeling to maintain its contractility, characterized by increased RV wall thickness, mass, and moderate dilatation, mediated by cardiomyocyte hypertrophy and extracellular matrix deposition. However, at some point during the course of persistent pressure overload, the compensatory mechanisms of the RV expire, and the RV fails (118).

In physiological conditions, HIF-1 α expression is significantly higher in the RV than the LV (119). RV HIF-1 α expression is increased in a number of animal models of PH including MCT rats (120), hypoxia exposed (HOX) rats (121), pulmonary artery banded (PAB) rats (122), SuHx rats (122) and pulmonary embolism (PE) rats (123). Rats with PE display increased RV HIF-1 α expression, and its level is positively correlated with RV hypertrophy and PAP (123). Interestingly, mice with *Hif2a* gain-of-function mutations develop RV hypertrophy but do not show signs of RV dilation despite of substantial increase in PAP, suggesting preserved RV function (111). In patients with repaired tetralogy of Fallot, the presence of gain-of-function mutations in HIF-1 α are associated with preserved RV function and better outcome due to increased transforming growth factor β 1 (*TGF β 1*) expression and myocardial fibrosis (124). Collectively, these reports suggest that presumably mild-to-moderate activation of both HIFs is associated with preserved RV function. By contrast, strong activation of HIFs adversely affects RV function. For example, mice with global inducible deletion of *Phd2* display increased mortality due to severe polycythemia and dilated cardiomyopathy (125). Similarly, Hif-2 activation in mice with EC-specific *Phd2* deletion leads to spontaneous PH with high mortality due to severe RV failure (108). However, the roles of HIFs and PHDs have not been studied in fixed afterload models of RV hypertrophy and failure using cell-specific gene knockout or overexpression.

Therapeutic potential of HIF targeting in PH

As we have discussed above, experiments in rodent models revealed that HIF-1/2 α exerts a profound impact on pulmonary vascular remodeling. Moreover, anti-sense oligonucleotides to *Hif2* (but not to *Hif1*) reduced vessel muscularization, rises in pulmonary artery pressures and RV hypertrophy in mice exposed to hypoxia, suggesting that inhibition of HIF-2 α can provide a therapeutic approach to prevent or reverse the development of PH (100). Thus, great interest has arisen in developing therapeutics targeting this pathway. Studies have specifically targeted components of the HIF pathway such as PHD2, HIF-1 α , or HIF-2 α with pharmacological agents in various rodent models of PH. Most tested agents that directly or indirectly inhibits HIFs have been able to prevent or reverse experimental PH (Table 3). Agents/compounds which inhibits HIF-1 α at the level of mRNA (topotecan and camptothecin), protein synthesis (2-methoxyestradiol (2ME2), Digoxin, Celastramycin, Caffeic acid phenethyl ester (CAPE)), protein accumulation and transcriptional activity (YC-1), and targeting the molecules regulating HIF axis (anti-CD146, mAb AA98, Apigenin), and inhibition of HIF-2 α at the level of mRNA (C-76), as well as the heterodimerization and DNA binding (PT2567) were evaluated. These inhibitors given via different routes (intra peritoneal, intravenous, subcutaneous, oral), were shown to preventive as well as reverse PH in various animal models of PH (hypoxia, MCT and SuHx). Notably, the HIF-2 α inhibitor C76 showed strong anti-remodeling effects in three experimental models of PH (27), indicating inhibition of HIF2 may be a promising therapeutic approach for PH.

Conclusions and Future Directions

Data obtained from cell systems, animal models, and patient-derived materials have consistently confirmed that HIF isoforms are important components of PH pathogenesis. The hypoxic and pseudo-hypoxic states that occur in different groups of PH may vary in intensity and duration, thus allowing an intricate interplay between HIF-1 and HIF-2 in driving the pathological processes that underlie pulmonary vascular and RV remodeling. Animal models have helped elucidate the non-redundant and complementary roles of HIF1 and HIF-2. For example, HIF-1 plays a major role in driving vasoconstriction, PASMC proliferation, angiogenesis, and RV contractility, whereas HIF-2 plays a major role in inflammatory cell recruitment, EC phenotypic switch to a pro-inflammatory state and to EndoMT. These data suggest dynamic regulation of HIF isoforms as well as cellular- and context-specific roles of HIF-1 and HIF-2 in the initiation, progression, and establishment

phases of pulmonary vascular and RV remodeling. Although head-to-head comparisons of mice with cell-specific deletions of HIF-1 α and HIF-2 α at different time points of hypoxic exposure is still needed to determine their influence on pulmonary vasculature and RV, it is conceivable that HIF-2 α may play a major role in the initiation of the disease, whereas HIF-1 α may play a major role in the progression and perpetuation of the disease. However, in cancers, HIF-1 α plays the dominant role in the response to acute hypoxia, whereas HIF-2 α drives the response to chronic hypoxia, although both are involved in cancer progression (126). Intriguingly, this HIF switch is also observed in pulmonary vascular endothelial and smooth muscle cells upon exposure to hypoxia (127), which may allow HIF-1 and HIF-2 to play divergent and complementary roles during hypoxic and pseudo-hypoxic responses of pulmonary vascular and cardiac cells in PH.

These contradicting data between knockout mouse models and *in vitro* cell models may be explained by acute exposure to hypoxia (maximum exposure of 1-4 days) in case of *in vitro* experiments or knockout studies in small animal models for PH (mice). Thus, further studies with inducible deletion of HIF isoforms in severe animal models of PH (MCT, SuHx in mice and rats) and in vascular cells isolated from PH patients and large animals (cows), which exhibit and maintain their unique phenotypes *in vitro* (44), are needed to provide deeper insights on cell type- and context-specific roles of HIF isoforms in PH. Furthermore, understanding the molecular mechanisms that determine HIF-1/2 switches or activation of cell type- and context-specific HIF isoforms in PH will facilitate a better understanding of the pathophysiological roles exerted by HIF isoforms and the potential clinical implications of targeting them. For example, PHD2 has relatively more influence on HIF-1 α , whereas PHD3 has relatively more influence on HIF-2 α (128). In addition, molecules like sirtuin 1, hypoxia-associated factor (HAF), and heat shock proteins (HSP70, HSP90) differentially regulated the degradation and activities of different HIF isoforms in various cell types (126, 129). Furthermore, translation of HIF-2 α (but not HIF-1 α) is linked to iron metabolism due to an iron-responsive element in the 5' untranslated region of HIF-2 α (130, 131). However, no studies to date have explored the mechanisms regulating the HIF-1/2 switch in pulmonary vascular and cardiac cells upon exposure to hypoxia and other non-hypoxic PH stimuli. Considering the pathophysiological roles of iron metabolism, sirtuins, and heat shock proteins in PH (132-135), the possibility that these mechanisms are operative in the putative HIF-1/2 switch associated with PH warrants further investigation.

Despite striking similarity in protein sequence, dimerization partners, and binding sites among HIF-1 α and HIF-2 α proteins, it is well-documented that HIF-1 and HIF-2 activate different subsets of hypoxia-inducible genes in various pathological conditions, including PH. Recent studies suggest that despite sharing an identical consensus recognition sequence, each HIF isoform has an inherent property that determines its binding distribution across the genome. For example: HIF-1 binds closer to promoters, while HIF-2 binds distal enhancers, and their inherent distributions are unaffected by the degree or duration of hypoxia or the cell type (136). In addition, differential recruitment of other transcription factors underlies HIF-mediated cell-specific hypoxia responses. Indeed, accumulating evidence suggests that HIF-1 α and HIF-2 α form separate multifactorial complexes with other transcription factors, co-factors, and RNA polymerase II to mediate the distinct functions of HIF-1 or HIF-2 (137). Hence, it is important to identify these complexes and their common and unique target genes, not only to understand the distinct pathological processes mediated by HIF isoforms, but also to selectively inhibit HIF isoform functions as a therapeutic approach.

In summary, rapidly advancing research has brought to light the isoform-specific, context-specific, and cell-specific roles of the HIF pathway in regulating pulmonary vascular remodeling. This has introduced a novel therapeutic approach for the treatment of PH. In line, HIF-2 selective inhibitors reversed PH in various animal models of PH without any significant side effects. Notably, a HIF-2-specific small molecule inhibitor developed to treat renal cancer has demonstrated a favorable safety profile in a recent Phase I trial (138), entered into Phase II clinical trials, and will be considered for clinical trials among PH patients in the future. Head-to-head comparisons and multi-center preclinical studies of pan-HIF inhibitors and HIF-1- and HIF-2-selective inhibitors in various animal models of PH and RV dysfunction are warranted before moving into clinical development (139). Notably, further studies are needed to develop personalized therapeutics i.e. to determine under what conditions and in which PH patients HIF inhibition can provide an optimal therapeutic strategy. In addition, given the myriad roles of HIFs and their possible influence on extrapulmonary manifestations in patients with PH (15, 140), it will be important to carefully assess the risk-to-benefit ratio of systemic vs. pulmonary selective HIF inhibitors. Thus, more work needs to be done to identify novel, potent and more specific inhibitors targeting clearly

defined points in the HIF pathway, followed by lung-selective delivery of these inhibitors will be the key for development of potential therapeutic strategy for PH.

Uncategorized References

1. Prabhakar NR, and Semenza GL. Adaptive and maladaptive cardiorespiratory responses to continuous and intermittent hypoxia mediated by hypoxia-inducible factors 1 and 2. *Physiol Rev.* 2012;92(3):967-1003.
2. Semenza GL. Oxygen sensing, hypoxia-inducible factors, and disease pathophysiology. *Annu Rev Pathol.* 2014;9:47-71.
3. Pullamsetti SS, Savai R, Seeger W, and Goncharova EA. Translational Advances in the Field of Pulmonary Hypertension. From Cancer Biology to New Pulmonary Arterial Hypertension Therapeutics. Targeting Cell Growth and Proliferation Signaling Hubs. *Am J Respir Crit Care Med.* 2017;195(4):425-37.
4. Humbert M, Guignabert C, Bonnet S, Dorfmüller P, Klinger JR, Nicolls MR, et al. Pathology and pathobiology of pulmonary hypertension: state of the art and research perspectives. *Eur Respir J.* 2019;53(1):1801887.
5. Neupane M, and Swenson ER. High-altitude pulmonary vascular diseases. *Advances in Pulmonary Hypertension.* 2017;15(3):149-57.
6. Wilkins MR, Ghofrani HA, Weissmann N, Aldashev A, and Zhao L. Pathophysiology and treatment of high-altitude pulmonary vascular disease. *Circulation.* 2015;131(6):582-90.
7. Fu X, and Zhang F. Role of the HIF-1 signaling pathway in chronic obstructive pulmonary disease. *Exp Ther Med.* 2018;16(6):4553-61.
8. Aquino-Galvez A, Gonzalez-Avila G, Jimenez-Sanchez LL, Maldonado-Martinez HA, Cisneros J, Toscano-Marquez F, et al. Dysregulated expression of hypoxia-inducible factors augments myofibroblasts differentiation in idiopathic pulmonary fibrosis. *Respir Res.* 2019;20(1):130.
9. Bonnet S, Michelakis ED, Porter CJ, Andrade-Navarro MA, Thebaud B, Bonnet S, et al. An abnormal mitochondrial-hypoxia inducible factor-1 α -Kv channel pathway disrupts oxygen sensing and triggers pulmonary arterial hypertension in fawn hooded rats: similarities to human pulmonary arterial hypertension. *Circulation.* 2006;113(22):2630-41.
10. Dai Z, Li M, Wharton J, Zhu MM, and Zhao YY. Prolyl-4 Hydroxylase 2 (PHD2) Deficiency in Endothelial Cells and Hematopoietic Cells Induces Obliterative Vascular Remodeling and Severe Pulmonary Arterial Hypertension in Mice and Humans Through Hypoxia-Inducible Factor-2 α . *Circulation.* 2016;133(24):2447-58.
11. Lei W, He Y, Shui X, Li G, Yan G, Zhang Y, et al. Expression and analyses of the HIF-1 pathway in the lungs of humans with pulmonary arterial hypertension. *Mol Med Rep.* 2016;14(5):4383-90.
12. El Kasmi KC, Pugliese SC, Riddle SR, Poth JM, Anderson AL, Frid MG, et al. Adventitial fibroblasts induce a distinct proinflammatory/profibrotic macrophage phenotype in pulmonary hypertension. *J Immunol.* 2014;193(2):597-609.
13. Tuder RM, Chacon M, Alger L, Wang J, Taraseviciene-Stewart L, Kasahara Y, et al. Expression of angiogenesis-related molecules in plexiform lesions in severe pulmonary hypertension: evidence for a process of disordered angiogenesis. *J Pathol.* 2001;195(3):367-74.
14. Wang M, Gu S, Liu Y, Yang Y, Yan J, Zhang X, et al. miRNA-PDGFRB/HIF1A-lncRNA CTEPHA1 Network Plays Important Roles in the Mechanism of Chronic Thromboembolic Pulmonary Hypertension. *Int Heart J.* 2019;60(4):924-37.

15. Garcia-Morales LJ, Chen NY, Weng T, Luo F, Davies J, Philip K, et al. Altered Hypoxic-Adenosine Axis and Metabolism in Group III Pulmonary Hypertension. *Am J Respir Cell Mol Biol*. 2016;54(4):574-83.
16. Bryant AJ, Carrick RP, McConaha ME, Jones BR, Shay SD, Moore CS, et al. Endothelial HIF signaling regulates pulmonary fibrosis-associated pulmonary hypertension. *American Journal of Physiology-Lung Cellular and Molecular Physiology*. 2015;310(3):L249-L62.
17. Huang Y, Boerema-de Munck A, Buscop-van Kempen M, Sluiter I, de Krijger R, Tibboel D, et al. Hypoxia inducible factor 2 α (HIF2 α /EPAS1) is associated with development of pulmonary hypertension in severe congenital diaphragmatic hernia patients. *Pulmonary circulation*. 2018;8(3):2045894018783734.
18. Han CF, Li ZY, and Li TH. Roles of hypoxia-inducible factor-1 α and its target genes in neonatal hypoxic pulmonary hypertension. *Eur Rev Med Pharmacol Sci*. 2017;21(18):4167-80.
19. Lemus-Varela M, Flores-Soto M, Cervantes-Munguia R, Torres-Mendoza B, Gudiño-Cabrera G, Chaparro-Huerta V, et al. Expression of HIF-1 α , VEGF and EPO in peripheral blood from patients with two cardiac abnormalities associated with hypoxia. *Clinical biochemistry*. 2010;43(3):234-9.
20. Farha S, Asosingh K, Xu W, Sharp J, George D, Comhair S, et al. Hypoxia-inducible factors in human pulmonary arterial hypertension: a link to the intrinsic myeloid abnormalities. *Blood*. 2011;117(13):3485-93.
21. Fijalkowska I, Xu W, Comhair SA, Janocha AJ, Mavrikis LA, Krishnamachary B, et al. Hypoxia inducible-factor1 α regulates the metabolic shift of pulmonary hypertensive endothelial cells. *Am J Pathol*. 2010;176(3):1130-8.
22. Kurosawa R, Satoh K, Kikuchi N, Kikuchi H, Saigusa D, Al-Mamun EA, et al. Identification of Celestramycin as a Novel Therapeutic Agent for Pulmonary Arterial Hypertension-High-throughput Screening of 5,562 Compounds. *Circulation research*. 2019.
23. Marsboom G, Toth PT, Ryan JJ, Hong Z, Wu X, Fang YH, et al. Dynamin-related protein 1-mediated mitochondrial mitotic fission permits hyperproliferation of vascular smooth muscle cells and offers a novel therapeutic target in pulmonary hypertension. *Circ Res*. 2012;110(11):1484-97.
24. Labrousse-Arias D, Castillo-Gonzalez R, Rogers NM, Torres-Capelli M, Barreira B, Aragonés J, et al. HIF-2 α -mediated induction of pulmonary thrombospondin-1 contributes to hypoxia-driven vascular remodelling and vasoconstriction. *Cardiovasc Res*. 2016;109(1):115-30.
25. Wang CC, Ying L, Barnes EA, Adams ES, Kim FY, Engel KW, et al. Pulmonary artery smooth muscle cell HIF-1 α regulates endothelin expression via microRNA-543. *Am J Physiol Lung Cell Mol Physiol*. 2018;315(3):L422-L31.
26. Barnes EA, Chen CH, Sedan O, and Cornfield DN. Loss of smooth muscle cell hypoxia inducible factor-1 α underlies increased vascular contractility in pulmonary hypertension. *FASEB J*. 2017;31(2):650-62.
27. Dai Z, Zhu MM, Peng Y, Machireddy N, Evans CE, Machado R, et al. Therapeutic Targeting of Vascular Remodeling and Right Heart Failure in Pulmonary Arterial Hypertension with a HIF-2 α Inhibitor. *Am J Respir Crit Care Med*. 2018;198(11):1423-34.
28. Tang H, Babicheva A, McDermott KM, Gu Y, Ayon RJ, Song S, et al. Endothelial HIF-2 α contributes to severe pulmonary hypertension due to endothelial-to-mesenchymal transition. *American Journal of Physiology-Lung Cellular and Molecular Physiology*. 2017;314(2):L256-L75.
29. Ang SO, Chen H, Gordeuk VR, Sergueeva AI, Polyakova LA, Miasnikova GY, et al. Endemic polycythemia in Russia: mutation in the VHL gene. *Blood Cells Mol Dis*. 2002;28(1):57-62.
30. Sarangi S, Lanikova L, Kapralova K, Acharya S, Swierczek S, Lipton JM, et al. The Homozygous VHL D126N Missense Mutation is Associated with Dramatically Elevated Erythropoietin Levels,

- Consequent Polycythemia, and Early Onset Severe Pulmonary Hypertension. *Pediatric Blood & Cancer*. 2014;61(11):2104-6.
31. Bond J, Gale DP, Connor T, Adams S, de Boer J, Gascoyne DM, et al. Dysregulation of the HIF pathway due to VHL mutation causing severe erythrocytosis and pulmonary arterial hypertension. *Blood*. 2011;117(13):3699-701.
 32. Caravita S, Deboeck G, Vachiere JL, and Naeije R. Pulmonary arterial hypertension associated with a von Hippel-Lindau gene mutation. *J Heart Lung Transplant*. 2016;35(9):1138-9.
 33. Bushuev VI, Miasnikova GY, Sergueeva AI, Polyakova LA, Okhotin D, Gaskin PR, et al. Endothelin-1, vascular endothelial growth factor and systolic pulmonary artery pressure in patients with Chuvash polycythemia. *Haematologica*. 2006;91(6):744-9.
 34. Dham N, Sable C, Okhotin D, Sergueeva A, Miasnikova G, Bushuev V, et al. Prospective assessment of pulmonary hypertension in children with Chuvash Polycythemia. *Blood*. 2007;110(11):1070a-a.
 35. Sable CA, Aliyu ZY, Dham N, Nourai M, Sachdev V, Sidenko S, et al. Pulmonary artery pressure and iron deficiency in patients with upregulation of hypoxia sensing due to homozygous VHRL200W mutation (Chuvash polycythemia). *Haematologica-the Hematology Journal*. 2012;97(2):193-200.
 36. Gale DP, Harten SK, Reid CD, Tuddenham EG, and Maxwell PH. Autosomal dominant erythrocytosis and pulmonary arterial hypertension associated with an activating HIF2 alpha mutation. *Blood*. 2008;112(3):919-21.
 37. Penalzoza D, and Arias-Stella J. The heart and pulmonary circulation at high altitudes: healthy highlanders and chronic mountain sickness. *Circulation*. 2007;115(9):1132-46.
 38. Peng Y, Cui C, He Y, Ouzhuluobu, Zhang H, Yang D, et al. Down-Regulation of EPAS1 Transcription and Genetic Adaptation of Tibetans to High-Altitude Hypoxia. *Mol Biol Evol*. 2017;34(4):818-30.
 39. Petousi N, Croft QP, Cavalleri GL, Cheng H-Y, Formenti F, Ishida K, et al. Tibetans living at sea level have a hyporesponsive hypoxia-inducible factor system and blunted physiological responses to hypoxia. *Journal of Applied Physiology*. 2013;116(7):893-904.
 40. Fish JE, Matouk CC, Yeboah E, Bevan SC, Khan M, Patil K, et al. Hypoxia-inducible expression of a natural cis-antisense transcript inhibits endothelial nitric-oxide synthase. *J Biol Chem*. 2007;282(21):15652-66.
 41. Cattaneo MG, Cappellini E, Benfante R, Ragni M, Omodeo-Sale F, Nisoli E, et al. Chronic deficiency of nitric oxide affects hypoxia inducible factor-1alpha (HIF-1alpha) stability and migration in human endothelial cells. *PLoS One*. 2011;6(12):e29680.
 42. BelAiba RS, Djordjevic T, Bonello S, Flugel D, Hess J, Kietzmann T, et al. Redox-sensitive regulation of the HIF pathway under non-hypoxic conditions in pulmonary artery smooth muscle cells. *Biol Chem*. 2004;385(3-4):249-57.
 43. Sun X, Kumar S, Sharma S, Aggarwal S, Lu Q, Gross C, et al. Endothelin-1 induces a glycolytic switch in pulmonary arterial endothelial cells via the mitochondrial translocation of endothelial nitric oxide synthase. *Am J Respir Cell Mol Biol*. 2014;50(6):1084-95.
 44. Pisarcik S, Maylor J, Lu W, Yun X, Udem C, Sylvester JT, et al. Activation of hypoxia-inducible factor-1 in pulmonary arterial smooth muscle cells by endothelin-1. *Am J Physiol Lung Cell Mol Physiol*. 2013;304(8):L549-61.
 45. Li M, Liu Y, Jin F, Sun X, Li Z, Liu Y, et al. Endothelin-1 induces hypoxia inducible factor 1alpha expression in pulmonary artery smooth muscle cells. *FEBS Lett*. 2012;586(21):3888-93.
 46. Yamashita T, Ohneda O, Nagano M, Iemitsu M, Makino Y, Tanaka H, et al. Abnormal heart development and lung remodeling in mice lacking the hypoxia-inducible factor-related basic helix-loop-helix PAS protein NEPAS. *Mol Cell Biol*. 2008;28(4):1285-97.

47. Liu J, Wang W, Wang L, Chen S, Tian B, Huang K, et al. IL-33 Initiates Vascular Remodelling in Hypoxic Pulmonary Hypertension by up-Regulating HIF-1alpha and VEGF Expression in Vascular Endothelial Cells. *EBioMedicine*. 2018;33:196-210.
48. Li C, Mpollo MS, Gonsalves CS, Tahara SM, Malik P, and Kalra VK. Peroxisome proliferator-activated receptor-alpha-mediated transcription of miR-199a2 attenuates endothelin-1 expression via hypoxia-inducible factor-1alpha. *J Biol Chem*. 2014;289(52):36031-47.
49. Patel N, Gonsalves CS, Malik P, and Kalra VK. Placenta growth factor augments endothelin-1 and endothelin-B receptor expression via hypoxia-inducible factor-1 alpha. *Blood*. 2008;112(3):856-65.
50. Gonsalves CS, Li C, Mpollo M-SEM, Pullarkat V, Malik P, Tahara SM, et al. Erythropoietin-mediated expression of placenta growth factor is regulated via activation of hypoxia-inducible factor-1 α and post-transcriptionally by miR-214 in sickle cell disease. *Biochemical Journal*. 2015;468(3):409-23.
51. Earley S, and Resta TC. Estradiol attenuates hypoxia-induced pulmonary endothelin-1 gene expression. *Am J Physiol Lung Cell Mol Physiol*. 2002;283(1):L86-93.
52. Frump AL, Selej M, Wood JA, Albrecht M, Yakubov B, Petrache I, et al. Hypoxia Upregulates Estrogen Receptor beta in Pulmonary Artery Endothelial Cells in a HIF-1alpha-Dependent Manner. *Am J Respir Cell Mol Biol*. 2018;59(1):114-26.
53. Morikawa M, Mitani Y, Holmborn K, Kato T, Koinuma D, Maruyama J, et al. The ALK-1/SMAD/ATOH8 axis attenuates hypoxic responses and protects against the development of pulmonary arterial hypertension. *Sci Signal*. 2019;12(607).
54. Ghosh G, Subramanian IV, Adhikari N, Zhang X, Joshi HP, Basi D, et al. Hypoxia-induced microRNA-424 expression in human endothelial cells regulates HIF-alpha isoforms and promotes angiogenesis. *J Clin Invest*. 2010;120(11):4141-54.
55. Luo Y, Teng X, Zhang L, Chen J, Liu Z, Chen X, et al. CD146-HIF-1 α hypoxic reprogramming drives vascular remodeling and pulmonary arterial hypertension. *Nature communications*. 2019;10(1):1-17.
56. Schultz K, Fanburg BL, and Beasley D. Hypoxia and hypoxia-inducible factor-1alpha promote growth factor-induced proliferation of human vascular smooth muscle cells. *Am J Physiol Heart Circ Physiol*. 2006;290(6):H2528-34.
57. Blum JI, Bijli KM, Murphy TC, Kleinhenz JM, and Hart CM. Time-dependent PPARgamma Modulation of HIF-1alpha Signaling in Hypoxic Pulmonary Artery Smooth Muscle Cells. *Am J Med Sci*. 2016;352(1):71-9.
58. Wang Y, Lu W, Yang K, Wang Y, Zhang J, Jia J, et al. Peroxisome proliferator-activated receptor gamma inhibits pulmonary hypertension targeting store-operated calcium entry. *J Mol Med (Berl)*. 2015;93(3):327-42.
59. Yue J, Guan J, Wang X, Zhang L, Yang Z, Ao Q, et al. MicroRNA-206 is involved in hypoxia-induced pulmonary hypertension through targeting of the HIF-1 α /Fhl-1 pathway. *Laboratory investigation*. 2013;93(7):748-59.
60. Chen M, Shen C, Zhang Y, and Shu H. MicroRNA-150 attenuates hypoxia-induced excessive proliferation and migration of pulmonary arterial smooth muscle cells through reducing HIF-1 α expression. *Biomedicine & pharmacotherapy*. 2017;93:861-8.
61. Jiang Y, Wang J, Tian H, Li G, Zhu H, Liu L, et al. Increased SUMO-1 expression in response to hypoxia: Interaction with HIF-1alpha in hypoxic pulmonary hypertension. *Int J Mol Med*. 2015;36(1):271-81.
62. Zhou F, Dai A, Jiang Y, Tan X, and Zhang X. SENP1 enhances hypoxia-induced proliferation of rat pulmonary artery smooth muscle cells by regulating hypoxia-inducible factor1alpha. *Mol Med Rep*. 2016;13(4):3482-90.

63. Pak O, Scheibe S, Esfandiary A, Gierhardt M, Sydykov A, Logan A, et al. Impact of the mitochondria-targeted antioxidant MitoQ on hypoxia-induced pulmonary hypertension. *Eur Respir J*. 2018.
64. Veit F, Pak O, Egemnazarov B, Roth M, Kosanovic D, Seimetz M, et al. Function of NADPH oxidase 1 in pulmonary arterial smooth muscle cells after monocrotaline-induced pulmonary vascular remodeling. *Antioxid Redox Signal*. 2013;19(18):2213-31.
65. Goyal P, Weissmann N, Grimminger F, Hegel C, Bader L, Rose F, et al. Upregulation of NAD(P)H oxidase 1 in hypoxia activates hypoxia-inducible factor 1 via increase in reactive oxygen species. *Free Radic Biol Med*. 2004;36(10):1279-88.
66. Sommer N, Strielkov I, Pak O, and Weissmann N. Oxygen sensing and signal transduction in hypoxic pulmonary vasoconstriction. *Eur Respir J*. 2016;47(1):288-303.
67. Wedgwood S, Lakshminrusimha S, Schumacker PT, and Steinhorn RH. Hypoxia inducible factor signaling and experimental persistent pulmonary hypertension of the newborn. *Front Pharmacol*. 2015;6(47):47.
68. Paulin R, Dromparis P, Sutendra G, Gurtu V, Zervopoulos S, Bowers L, et al. Sirtuin 3 deficiency is associated with inhibited mitochondrial function and pulmonary arterial hypertension in rodents and humans. *Cell Metab*. 2014;20(5):827-39.
69. Dabral S, Muecke C, Valasarajan C, Schmoranzler M, Wietelmann A, Semenza GL, et al. A RASSF1A-HIF1alpha loop drives Warburg effect in cancer and pulmonary hypertension. *Nature communications*. 2019;10(1):2130.
70. He M, Ma S, Cai Q, Wu Y, Shao C, Kong H, et al. Hypoxia induces the dysfunction of human endothelial colony-forming cells via HIF-1alpha signaling. *Respir Physiol Neurobiol*. 2018;247:87-95.
71. Bertero T, Lu Y, Annis S, Hale A, Bhat B, Saggari R, et al. Systems-level regulation of microRNA networks by miR-130/301 promotes pulmonary hypertension. *J Clin Invest*. 2014;124(8):3514-28.
72. Marín-Hernández A, Gallardo-Pérez JC, Ralph SJ, Rodríguez-Enríquez S, and Moreno-Sánchez R. HIF-1alpha modulates energy metabolism in cancer cells by inducing over-expression of specific glycolytic isoforms. *Mini reviews in medicinal chemistry*. 2009;9(9):1084-101.
73. Tang H, Babicheva A, McDermott KM, Gu Y, Ayon RJ, Song S, et al. Endothelial HIF-2alpha contributes to severe pulmonary hypertension due to endothelial-to-mesenchymal transition. *American Journal of Physiology-Lung Cellular and Molecular Physiology*. 2018;314(2):L256-L75.
74. Cowburn AS, Crosby A, Macias D, Branco C, Colaço RD, Southwood M, et al. HIF2alpha-arginase axis is essential for the development of pulmonary hypertension. *Proceedings of the National Academy of Sciences*. 2016;113(31):8801-6.
75. Krotova K, Patel JM, Block ER, and Zharikov S. Hypoxic upregulation of arginase II in human lung endothelial cells. *Am J Physiol Cell Physiol*. 2010;299(6):C1541-8.
76. Jung C, Grun K, Betge S, Pernow J, Kelm M, Muessig J, et al. Arginase Inhibition Reverses Monocrotaline-Induced Pulmonary Hypertension. *Int J Mol Sci*. 2017;18(8).
77. Skuli N, Majmundar AJ, Krock BL, Mesquita RC, Mathew LK, Quinn ZL, et al. Endothelial HIF-2alpha regulates murine pathological angiogenesis and revascularization processes. *J Clin Invest*. 2012;122(4):1427-43.
78. Jiang X, Tian W, Tu AB, Pasupneti S, Shuffle E, Dahms P, et al. Endothelial hypoxia-inducible factor-2alpha is required for the maintenance of airway microvasculature. *Circulation*. 2019;139(4):502-17.
79. Shan F, Li J, and Huang QY. HIF-1 alpha-induced up-regulation of miR-9 contributes to phenotypic modulation in pulmonary artery smooth muscle cells during hypoxia. *J Cell Physiol*. 2014;229(10):1511-20.

80. Zeng Y, Liu H, Kang K, Wang Z, Hui G, Zhang X, et al. Hypoxia inducible factor-1 mediates expression of miR-322: potential role in proliferation and migration of pulmonary arterial smooth muscle cells. *Sci Rep*. 2015;5:12098.
81. Gou D, Ramchandran R, Peng X, Yao L, Kang K, Sarkar J, et al. miR-210 has an antiapoptotic effect in pulmonary artery smooth muscle cells during hypoxia. *American Journal of Physiology-Lung Cellular and Molecular Physiology*. 2012;303(8):L682-L91.
82. Labrousse-Arias D, Castillo-Gonzalez R, Rogers NM, Torres-Capelli M, Barreira B, Aragonés J, et al. HIF-2 α -mediated induction of pulmonary thrombospondin-1 contributes to hypoxia-driven vascular remodelling and vasoconstriction. *Cardiovascular research*. 2016;109(1):115-30.
83. Sheikh AQ, Lighthouse JK, and Greif DM. Recapitulation of developing artery muscularization in pulmonary hypertension. *Cell Rep*. 2014;6(5):809-17.
84. Sheikh AQ, Misra A, Rosas IO, Adams RH, and Greif DM. Smooth muscle cell progenitors are primed to muscularize in pulmonary hypertension. *Sci Transl Med*. 2015;7(308):308ra159.
85. Sheikh AQ, Saddouk FZ, Ntokou A, Mazurek R, and Greif DM. Cell Autonomous and Non-cell Autonomous Regulation of SMC Progenitors in Pulmonary Hypertension. *Cell Rep*. 2018;23(4):1152-65.
86. Wang J, Weigand L, Lu W, Sylvester JT, Semenza GL, and Shimoda LA. Hypoxia inducible factor 1 mediates hypoxia-induced TRPC expression and elevated intracellular Ca²⁺ in pulmonary arterial smooth muscle cells. *Circ Res*. 2006;98(12):1528-37.
87. Whitman EM, Pisarcik S, Luke T, Fallon M, Wang J, Sylvester JT, et al. Endothelin-1 mediates hypoxia-induced inhibition of voltage-gated K⁺ channel expression in pulmonary arterial myocytes. *Am J Physiol Lung Cell Mol Physiol*. 2008;294(2):L309-18.
88. Ahn YT, Kim YM, Adams E, Lyu SC, Alvira CM, and Cornfield DN. Hypoxia-inducible factor-1 α regulates KCNMB1 expression in human pulmonary artery smooth muscle cells. *Am J Physiol Lung Cell Mol Physiol*. 2012;302(3):L352-9.
89. Eul B, Rose F, Krick S, Savai R, Goyal P, Klepetko W, et al. Impact of HIF-1 α and HIF-2 α on proliferation and migration of human pulmonary artery fibroblasts in hypoxia. *FASEB J*. 2006;20(1):163-5.
90. Krick S, Hanze J, Eul B, Savai R, Seay U, Grimminger F, et al. Hypoxia-driven proliferation of human pulmonary artery fibroblasts: cross-talk between HIF-1 α and an autocrine angiotensin system. *FASEB J*. 2005;19(7):857-9.
91. Zhang R, Wu Y, Zhao M, Liu C, Zhou L, Shen S, et al. Role of HIF-1 α in the regulation ACE and ACE2 expression in hypoxic human pulmonary artery smooth muscle cells. *Am J Physiol Lung Cell Mol Physiol*. 2009;297(4):L631-40.
92. Zhang R, Su H, Ma X, Xu X, Liang L, Ma G, et al. MiRNA let-7b promotes the development of hypoxic pulmonary hypertension by targeting ACE2. *Am J Physiol Lung Cell Mol Physiol*. 2019;316(3):L547-L57.
93. Rabinovitch M, Guignabert C, Humbert M, and Nicolls MR. Inflammation and immunity in the pathogenesis of pulmonary arterial hypertension. *Circ Res*. 2014;115(1):165-75.
94. Takeda K, Ho VC, Takeda H, Duan LJ, Nagy A, and Fong GH. Placental but not heart defects are associated with elevated hypoxia-inducible factor alpha levels in mice lacking prolyl hydroxylase domain protein 2. *Mol Cell Biol*. 2006;26(22):8336-46.
95. Iyer NV, Kotch LE, Agani F, Leung SW, Laughner E, Wenger RH, et al. Cellular and developmental control of O₂ homeostasis by hypoxia-inducible factor 1 alpha. *Genes Dev*. 1998;12(2):149-62.
96. Tian H, Hammer RE, Matsumoto AM, Russell DW, and McKnight SL. The hypoxia-responsive transcription factor EPAS1 is essential for catecholamine homeostasis and protection against heart failure during embryonic development. *Genes & Development*. 1998;12(21):3320-4.

97. Maltepe E, Schmidt JV, Baunoch D, Bradfield CA, and Simon MC. Abnormal angiogenesis and responses to glucose and oxygen deprivation in mice lacking the protein ARNT. *Nature*. 1997;386(6623):403-7.
98. Aimee YY, Shimoda LA, Iyer NV, Huso DL, Sun X, McWilliams R, et al. Impaired physiological responses to chronic hypoxia in mice partially deficient for hypoxia-inducible factor 1 α . *The Journal of clinical investigation*. 1999;103(5):691-6.
99. Brusselmans K, Compennolle V, Tjwa M, Wiesener MS, Maxwell PH, Collen D, et al. Heterozygous deficiency of hypoxia-inducible factor-2 α protects mice against pulmonary hypertension and right ventricular dysfunction during prolonged hypoxia. *J Clin Invest*. 2003;111(10):1519-27.
100. Hu CJ, Poth JM, Zhang H, Flockton A, Laux A, Kumar S, et al. Suppression of HIF2 signalling attenuates the initiation of hypoxia-induced pulmonary hypertension. *Eur Respir J*. 2019;54(6).
101. Ball MK, Waypa GB, Mungai PT, Nielsen JM, Czech L, Dudley VJ, et al. Regulation of hypoxia-induced pulmonary hypertension by vascular smooth muscle hypoxia-inducible factor-1 α . *American journal of respiratory and critical care medicine*. 2014;189(3):314-24.
102. Kim Y-M, Barnes EA, Alvira CM, Ying L, Reddy S, and Cornfield DN. Hypoxia-inducible factor-1 α in pulmonary artery smooth muscle cells lowers vascular tone by decreasing myosin light chain phosphorylation. *Circulation research*. 2013;112(9):1230-3.
103. Tang H, Babicheva A, McDermott KM, Gu Y, Ayon RJ, Song S, et al. Endothelial HIF-2 α contributes to severe pulmonary hypertension due to endothelial-to-mesenchymal transition. *American journal of physiology Lung cellular and molecular physiology*. 2018;314(2):L256-L75.
104. Sheikh AQ, Saddouk FZ, Ntokou A, Mazurek R, and Greif DM. Cell autonomous and non-cell autonomous regulation of SMC progenitors in pulmonary hypertension. *Cell reports*. 2018;23(4):1152-65.
105. Skuli N, Liu L, Runge A, Wang T, Yuan L, Patel S, et al. Endothelial deletion of hypoxia-inducible factor-2 α (HIF-2 α) alters vascular function and tumor angiogenesis. *Blood*. 2009;114(2):469-77.
106. Bryant AJ, Carrick RP, McConaha ME, Jones BR, Shay SD, Moore CS, et al. Endothelial HIF signaling regulates pulmonary fibrosis-associated pulmonary hypertension. *Am J Physiol Lung Cell Mol Physiol*. 2016;310(3):L249-62.
107. Payne S, De Val S, and Neal A. Endothelial-Specific Cre Mouse Models: Is Your Cre CREdible? *Arteriosclerosis, thrombosis, and vascular biology*. 2018;38(11):2550-61.
108. Dai Z, Li M, Wharton J, Zhu MM, and Zhao Y-Y. Prolyl-4 hydroxylase 2 (PHD2) deficiency in endothelial cells and hematopoietic cells induces obliterative vascular remodeling and severe pulmonary arterial hypertension in mice and humans through hypoxia-inducible factor-2 α . *Circulation*. 2016;133(24):2447-58.
109. Kapitsinou PP, Rajendran G, Astleford L, Michael M, Schonfeld MP, Fields T, et al. The Endothelial Prolyl-4-Hydroxylase Domain 2/Hypoxia-Inducible Factor 2 Axis Regulates Pulmonary Artery Pressure in Mice. *Mol Cell Biol*. 2016;36(10):1584-94.
110. Wang S, Zeng H, Xie XJ, Tao YK, He X, Roman RJ, et al. Loss of prolyl hydroxylase domain protein 2 in vascular endothelium increases pericyte coverage and promotes pulmonary arterial remodeling. *Oncotarget*. 2016;7(37):58848-61.
111. Tan Q, Kerestes H, Percy MJ, Pietrofesa R, Chen L, Khurana TS, et al. Erythrocytosis and pulmonary hypertension in a mouse model of human HIF2A gain of function mutation. *J Biol Chem*. 2013;288(24):17134-44.
112. Hickey MM, Richardson T, Wang T, Mosqueira M, Arguiri E, Yu H, et al. The von Hippel-Lindau Chuvash mutation promotes pulmonary hypertension and fibrosis in mice. *J Clin Invest*. 2010;120(3):827-39.

113. Dai Z, Li M, Wharton J, Zhu MM, and Zhao YY. Prolyl-4 Hydroxylase 2 (PHD2) Deficiency in Endothelial Cells and Hematopoietic Cells Induces Obliterative Vascular Remodeling and Severe Pulmonary Arterial Hypertension in Mice and Humans Through Hypoxia-Inducible Factor-2 α . *Circulation*. 2016;133(24):2447-58.
114. Kojima H, Tokunou T, Takahara Y, Sunagawa K, Hirooka Y, Ichiki T, et al. Hypoxia-inducible factor-1 alpha deletion in myeloid lineage attenuates hypoxia-induced pulmonary hypertension. *Physiol Rep*. 2019;7(7):e14025.
115. Yu YA, Malakhau Y, Yu CA, Phelan SJ, Cumming RI, Kan MJ, et al. Nonclassical Monocytes Sense Hypoxia, Regulate Pulmonary Vascular Remodeling, and Promote Pulmonary Hypertension. *J Immunol*. 2020;204(6):1474-85.
116. Yamamoto A, Hester J, Macklin PS, Kawai K, Uchiyama M, Biggs D, et al. Systemic silencing of PHD2 causes reversible immune regulatory dysfunction. *J Clin Invest*. 2019;129(9):3640-56.
117. Tamosiuniene R, Tian W, Dhillon G, Wang L, Sung YK, Gera L, et al. Regulatory T cells limit vascular endothelial injury and prevent pulmonary hypertension. *Circ Res*. 2011;109(8):867-79.
118. Lahm T, Douglas IS, Archer SL, Bogaard HJ, Chesler NC, Haddad F, et al. Assessment of Right Ventricular Function in the Research Setting: Knowledge Gaps and Pathways Forward. An Official American Thoracic Society Research Statement. *Am J Respir Crit Care Med*. 2018;198(4):e15-e43.
119. Tekin D, Dursun AD, Bastug M, Karaorman G, and Ficicilar H. The effects of acute and intermittent hypoxia on the expressions of HIF-1 α and VEGF in the left and right ventricles of the rabbit heart. *Anadolu Kardiyol Derg*. 2011;11(5):379-85.
120. Adao R, Mendes-Ferreira P, Santos-Ribeiro D, Maia-Rocha C, Pimentel LD, Monteiro-Pinto C, et al. Urocortin-2 improves right ventricular function and attenuates pulmonary arterial hypertension. *Cardiovasc Res*. 2018;114(8):1165-77.
121. Zhang S, Ma K, Liu Y, Pan X, Chen Q, Qi L, et al. Stabilization of Hypoxia-inducible Factor by DMOG Inhibits Development of Chronic Hypoxia-Induced Right Ventricular Remodeling. *J Cardiovasc Pharmacol*. 2016;67(1):68-75.
122. Bogaard HJ, Natarajan R, Henderson SC, Long CS, Kraskauskas D, Smithson L, et al. Chronic pulmonary artery pressure elevation is insufficient to explain right heart failure. *Circulation*. 2009;120(20):1951-60.
123. Liu W, Zhang Y, Lu L, Wang L, Chen M, and Hu T. Expression and Correlation of Hypoxia-Inducible Factor-1 α (HIF-1 α) with Pulmonary Artery Remodeling and Right Ventricular Hypertrophy in Experimental Pulmonary Embolism. *Med Sci Monit*. 2017;23:2083-8.
124. Jeewa A, Manickaraj AK, Mertens L, Manlhiot C, Kinneer C, Mondal T, et al. Genetic determinants of right-ventricular remodeling after tetralogy of Fallot repair. *Pediatr Res*. 2012;72(4):407-13.
125. Minamishima YA, Moslehi J, Bardeesy N, Cullen D, Bronson RT, and Kaelin WG, Jr. Somatic inactivation of the PHD2 prolyl hydroxylase causes polycythemia and congestive heart failure. *Blood*. 2008;111(6):3236-44.
126. Koh MY, Lemos R, Jr., Liu X, and Powis G. The hypoxia-associated factor switches cells from HIF-1 α - to HIF-2 α -dependent signaling promoting stem cell characteristics, aggressive tumor growth and invasion. *Cancer Res*. 2011;71(11):4015-27.
127. Bartoszewski R, Moszynska A, Serocki M, Cabaj A, Polten A, Ochocka R, et al. Primary endothelial cell-specific regulation of hypoxia-inducible factor (HIF)-1 and HIF-2 and their target gene expression profiles during hypoxia. *Faseb Journal*. 2019;33(7):7929-41.
128. Appelhoff RJ, Tian YM, Raval RR, Turley H, Harris AL, Pugh CW, et al. Differential function of the prolyl hydroxylases PHD1, PHD2, and PHD3 in the regulation of hypoxia-inducible factor. *J Biol Chem*. 2004;279(37):38458-65.

129. Koh MY, and Powis G. Passing the baton: the HIF switch. *Trends Biochem Sci.* 2012;37(9):364-72.
130. Rankin EB, Biju MP, Liu Q, Unger TL, Rha J, Johnson RS, et al. Hypoxia-inducible factor-2 (HIF-2) regulates hepatic erythropoietin in vivo. *J Clin Invest.* 2007;117(4):1068-77.
131. Sanchez M, Galy B, Muckenthaler MU, and Hentze MW. Iron-regulatory proteins limit hypoxia-inducible factor-2 α expression in iron deficiency. *Nat Struct Mol Biol.* 2007;14(5):420-6.
132. Paulin R, Dromparis P, Sutendra G, Gurtu V, Zervopoulos S, Bowers L, et al. Sirtuin 3 deficiency is associated with inhibited mitochondrial function and pulmonary arterial hypertension in rodents and humans. *Cell metabolism.* 2014;20(5):827-39.
133. Lim JH, Lee YM, Chun YS, Chen J, Kim JE, and Park JW. Sirtuin 1 modulates cellular responses to hypoxia by deacetylating hypoxia-inducible factor 1 α . *Mol Cell.* 2010;38(6):864-78.
134. Liu YV, Baek JH, Zhang H, Diez R, Cole RN, and Semenza GL. RACK1 competes with HSP90 for binding to HIF-1 α and is required for O₂-independent and HSP90 inhibitor-induced degradation of HIF-1 α . *Molecular cell.* 2007;25(2):207-17.
135. Sanchez M, Galy B, Muckenthaler MU, and Hentze MW. Iron-regulatory proteins limit hypoxia-inducible factor-2 α expression in iron deficiency. *Nature structural & molecular biology.* 2007;14(5):420-6.
136. Smythies JA, Sun M, Masson N, Salama R, Simpson PD, Murray E, et al. Inherent DNA-binding specificities of the HIF-1 α and HIF-2 α transcription factors in chromatin. *EMBO Rep.* 2019;20(1).
137. Pawlus MR, and Hu CJ. Enhanceosomes as integrators of hypoxia inducible factor (HIF) and other transcription factors in the hypoxic transcriptional response. *Cell Signal.* 2013;25(9):1895-903.
138. Courtney KD, Infante JR, Lam ET, Figlin RA, Rini BI, Brugarolas J, et al. Phase I Dose-Escalation Trial of PT2385, a First-in-Class Hypoxia-Inducible Factor-2 α Antagonist in Patients With Previously Treated Advanced Clear Cell Renal Cell Carcinoma. *J Clin Oncol.* 2018;36(9):867-74.
139. Provencher S, Archer SL, Ramirez FD, Hibbert B, Paulin R, Boucherat O, et al. Standards and Methodological Rigor in Pulmonary Arterial Hypertension Preclinical and Translational Research. *Circ Res.* 2018;122(7):1021-32.
140. Nickel NP, Yuan K, Dorfmueller P, Provencher S, Lai YC, Bonnet S, et al. Beyond the Lungs: Systemic Manifestations of Pulmonary Arterial Hypertension. *Am J Respir Crit Care Med.* 2020;201(2):148-57.
141. Chen T, Zhou Q, Tang H, Bozkanat M, Yuan JX, Raj JU, et al. miR-17/20 Controls Prolyl Hydroxylase 2 (PHD2)/Hypoxia-Inducible Factor 1 (HIF1) to Regulate Pulmonary Artery Smooth Muscle Cell Proliferation. *J Am Heart Assoc.* 2016;5(12).
142. Deng B, Du J, Hu R, Wang A-P, Wu W-H, Hu C-P, et al. MicroRNA-103/107 is involved in hypoxia-induced proliferation of pulmonary arterial smooth muscle cells by targeting HIF-1 β . *Life sciences.* 2016;147:117-24.
143. Luo Y, Teng X, Zhang L, Chen J, Liu Z, Chen X, et al. CD146-HIF-1 α hypoxic reprogramming drives vascular remodeling and pulmonary arterial hypertension. *Nature communications.* 2019;10(1):3551.
144. Liu P, Gu Y, Luo J, Ye P, Zheng Y, Yu W, et al. Inhibition of Src activation reverses pulmonary vascular remodeling in experimental pulmonary arterial hypertension via Akt/mTOR/HIF-1 α signaling pathway. *Exp Cell Res.* 2019;380(1):36-46.
145. Yao L, Nie X, Shi S, Song S, Hao X, Li S, et al. Reciprocal regulation of HIF-1 α and 15-LO/15-HETE promotes anti-apoptosis process in pulmonary artery smooth muscle cells during hypoxia. *Prostaglandins Other Lipid Mediat.* 2012;99(3-4):96-106.
146. Li X, He Y, Xu Y, Huang X, Liu J, Xie M, et al. KLF5 mediates vascular remodeling via HIF-1 α in hypoxic pulmonary hypertension. *Am J Physiol Lung Cell Mol Physiol.* 2016;310(4):L299-310.

147. Diebold I, Petry A, Djordjevic T, Belaiba RS, Fineman J, Black S, et al. Reciprocal regulation of Rac1 and PAK-1 by HIF-1alpha: a positive-feedback loop promoting pulmonary vascular remodeling. *Antioxid Redox Signal*. 2010;13(4):399-412.
148. Fukai K, Nakamura A, Hoshino A, Nakanishi N, Okawa Y, Ariyoshi M, et al. Pyk2 aggravates hypoxia-induced pulmonary hypertension by activating HIF-1alpha. *Am J Physiol Heart Circ Physiol*. 2015;308(8):H951-9.
149. Jiang Y, Wang J, Tian H, Li G, Zhu H, Liu L, et al. Increased SUMO-1 expression in response to hypoxia: Interaction with HIF-1 α in hypoxic pulmonary hypertension. *International journal of molecular medicine*. 2015;36(1):271-81.
150. Pekarova M, Koudelka A, Kolarova H, Ambrozova G, Klinke A, Cerna A, et al. Asymmetric dimethyl arginine induces pulmonary vascular dysfunction via activation of signal transducer and activator of transcription 3 and stabilization of hypoxia-inducible factor 1-alpha. *Vascul Pharmacol*. 2015;73:138-48.
151. Michaud MD, Robitaille GA, Gratton JP, and Richard DE. Sphingosine-1-phosphate: a novel nonhypoxic activator of hypoxia-inducible factor-1 in vascular cells. *Arterioscler Thromb Vasc Biol*. 2009;29(6):902-8.
152. Zhang Z, Li Z, Wang Y, Wei L, and Chen H. Overexpressed long noncoding RNA CPS1-IT alleviates pulmonary arterial hypertension in obstructive sleep apnea by reducing interleukin-1beta expression via HIF1 transcriptional activity. *J Cell Physiol*. 2019;234(11):19715-27.
153. Ghosh MC, Zhang D-L, Jeong SY, Kovtunovych G, Ollivierre-Wilson H, Noguchi A, et al. Deletion of iron regulatory protein 1 causes polycythemia and pulmonary hypertension in mice through translational derepression of HIF2 α . *Cell metabolism*. 2013;17(2):271-81.
154. Johns RA, Takimoto E, Meuchel LW, Elsaigh E, Zhang A, Heller NM, et al. Hypoxia-Inducible Factor 1 α Is a Critical Downstream Mediator for Hypoxia-Induced Mitogenic Factor (FIZZ1/RELM α)–Induced Pulmonary Hypertension. *Arteriosclerosis, thrombosis, and vascular biology*. 2016;36(1):134-44.
155. Hu C-J, Poth JM, Zhang H, Flockton A, Laux A, Kumar S, et al. Suppression of HIF2 signalling attenuates the initiation of hypoxia-induced pulmonary hypertension. *European Respiratory Journal*. 2019;54(6).
156. Cowburn AS, Crosby A, Macias D, Branco C, Colaco RD, Southwood M, et al. HIF2alpha-arginase axis is essential for the development of pulmonary hypertension. *Proc Natl Acad Sci U S A*. 2016;113(31):8801-6.
157. Kim YM, Barnes EA, Alvira CM, Ying L, Reddy S, and Cornfield DN. Hypoxia-inducible factor-1alpha in pulmonary artery smooth muscle cells lowers vascular tone by decreasing myosin light chain phosphorylation. *Circ Res*. 2013;112(9):1230-3.
158. Ball MK, Waypa GB, Mungai PT, Nielsen JM, Czech L, Dudley VJ, et al. Regulation of hypoxia-induced pulmonary hypertension by vascular smooth muscle hypoxia-inducible factor-1alpha. *Am J Respir Crit Care Med*. 2014;189(3):314-24.
159. Yen-Rei AY, Malakhau Y, Chen-Hsin AY, Phelan S-LJ, Cumming RI, Kan MJ, et al. Nonclassical Monocytes Sense Hypoxia, Regulate Pulmonary Vascular Remodeling, and Promote Pulmonary Hypertension. *The Journal of Immunology*. 2020.
160. Song D, Navalsky BE, Guan W, Ingersoll C, Wang T, Loro E, et al. Tibetan PHD2, an allele with loss-of-function properties. *Proc Natl Acad Sci U S A*. 2020;117(22):12230-8.
161. Chen T, Zhou Q, Tang H, Bozkanat M, Yuan JXJ, Raj JU, et al. miR-17/20 Controls Prolyl Hydroxylase 2 (PHD 2)/Hypoxia-Inducible Factor 1 (HIF 1) to Regulate Pulmonary Artery Smooth Muscle Cell Proliferation. *Journal of the American Heart Association*. 2016;5(12):e004510.
162. Johns RA, Takimoto E, Meuchel LW, Elsaigh E, Zhang A, Heller NM, et al. Hypoxia-Inducible Factor 1alpha Is a Critical Downstream Mediator for Hypoxia-Induced Mitogenic Factor

- (FIZZ1/RELMalpha)-Induced Pulmonary Hypertension. *Arterioscler Thromb Vasc Biol.* 2016;36(1):134-44.
163. Macias D, Cowburn AS, Torres-Torrelo H, Ortega-Sáenz P, López-Barneo J, and Johnson RS. HIF-2 α is essential for carotid body development and function. *eLife.* 2018;7:e34681.
164. Docherty CK, Nilsen M, and MacLean MR. Influence of 2-Methoxyestradiol and Sex on Hypoxia-Induced Pulmonary Hypertension and Hypoxia-Inducible Factor-1-alpha. *J Am Heart Assoc.* 2019;8(5):e011628.
165. Jiang Y, Zhou Y, Peng G, Liu N, Tian H, Pan D, et al. Topotecan prevents hypoxia-induced pulmonary arterial hypertension and inhibits hypoxia-inducible factor-1alpha and TRPC channels. *Int J Biochem Cell Biol.* 2018;104:161-70.
166. Abud EM, Maylor J, Undem C, Punjabi A, Zaiman AL, Myers AC, et al. Digoxin inhibits development of hypoxic pulmonary hypertension in mice. *Proc Natl Acad Sci U S A.* 2012;109(4):1239-44.
167. Cheng C-C, Chi P-L, Shen M-C, Shu C-W, Wann S-R, Liu C-P, et al. Caffeic Acid Phenethyl Ester Rescues Pulmonary Arterial Hypertension through the Inhibition of AKT/ERK-Dependent PDGF/HIF-1 α In Vitro and In Vivo. *International journal of molecular sciences.* 2019;20(6):1468.
168. Kurosawa R, Satoh K, Kikuchi N, Kikuchi H, Saigusa D, Al-Mamun ME, et al. Identification of Celastramycin as a Novel Therapeutic Agent for Pulmonary Arterial Hypertension-High-throughput Screening of 5,562 Compounds. *Circ Res.* 2019;125(3):309-27.
169. Huh JW, Kim SY, Lee JH, and Lee YS. YC-1 attenuates hypoxia-induced pulmonary arterial hypertension in mice. *Pulm Pharmacol Ther.* 2011;24(6):638-46.
170. He Y, Fang X, Shi J, Li X, Xie M, and Liu X. Apigenin attenuates pulmonary hypertension by inducing mitochondria-dependent apoptosis of PSMCs via inhibiting the hypoxia inducible factor 1alpha-KV1.5 channel pathway. *Chem Biol Interact.* 2020;317:108942.

Figure 1

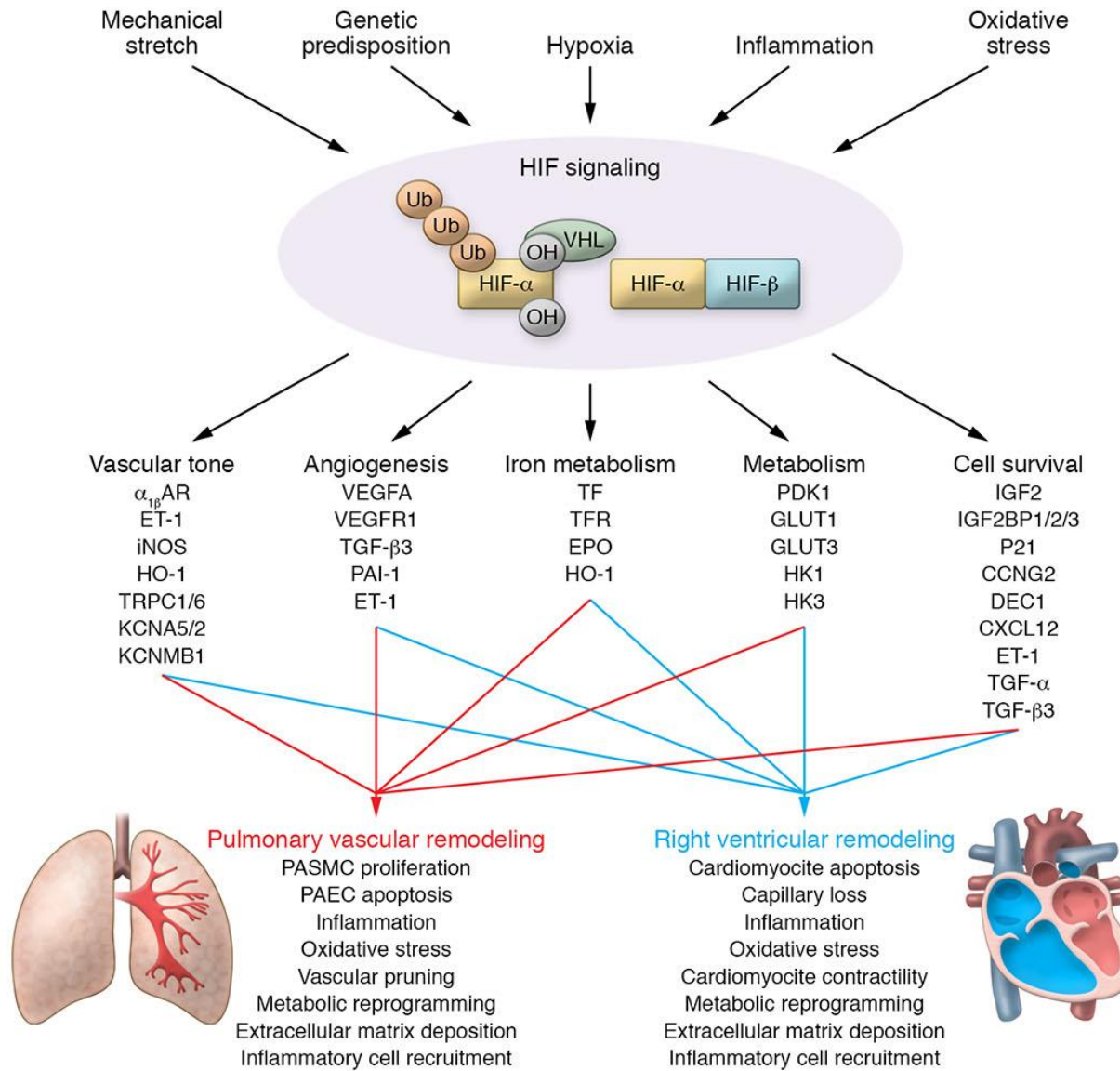

Figure 1. Emerging concepts of HIF signaling in pulmonary hypertension. Emerging evidence shows that many pro-PH factors apart from hypoxia, such as inflammation, mechanical stretch, oxidative stress, and genetic predisposition converge on HIF signaling pathways, causing alterations in vascular tone, angiogenesis, metabolism, and cell survival that subsequently lead to pulmonary vascular and right ventricular remodeling. VHL, von Hippel–Lindau tumor suppressor; PHD2, prolyl hydroxylase domain 2; α 1 β -AR, alpha 1 beta-adrenergic receptor; ET-1, endothelin 1; HO-1, heme oxygenase-1; TRPC1, transient receptor potential canonical 1; TRPC6, transient receptor potential canonical 6; KCNA5, potassium voltage-gated channel, shaker-related subfamily, member 5; KCNA2, potassium voltage-gated channel, shaker-related subfamily, member 2; KCNMB1, calcium-activated potassium channel subunit beta-1; PAI-1, plasminogen activator inhibitor-1; TF, transferrin; TFR, transferrin receptor; EPO, erythropoietin; PDK1, pyruvate dehydrogenase kinase 1; GLUT1, glucose transporter 1; GLUT3, glucose transporter 3; HK1, hexokinase 1; HK3, hexokinase 3; IGF2BP1, insulin-like growth factor 2 mRNA-binding protein 1; IGF2BP2, insulin-like growth factor 2 mRNA-binding protein 3; IGF2BP3, insulin-like growth factor 2 mRNA-binding protein 3; p21, cyclin-dependent kinase inhibitor 1; CCNG2, cyclin-G2; DEC1, deleted in esophageal cancer 1.

Figure 2

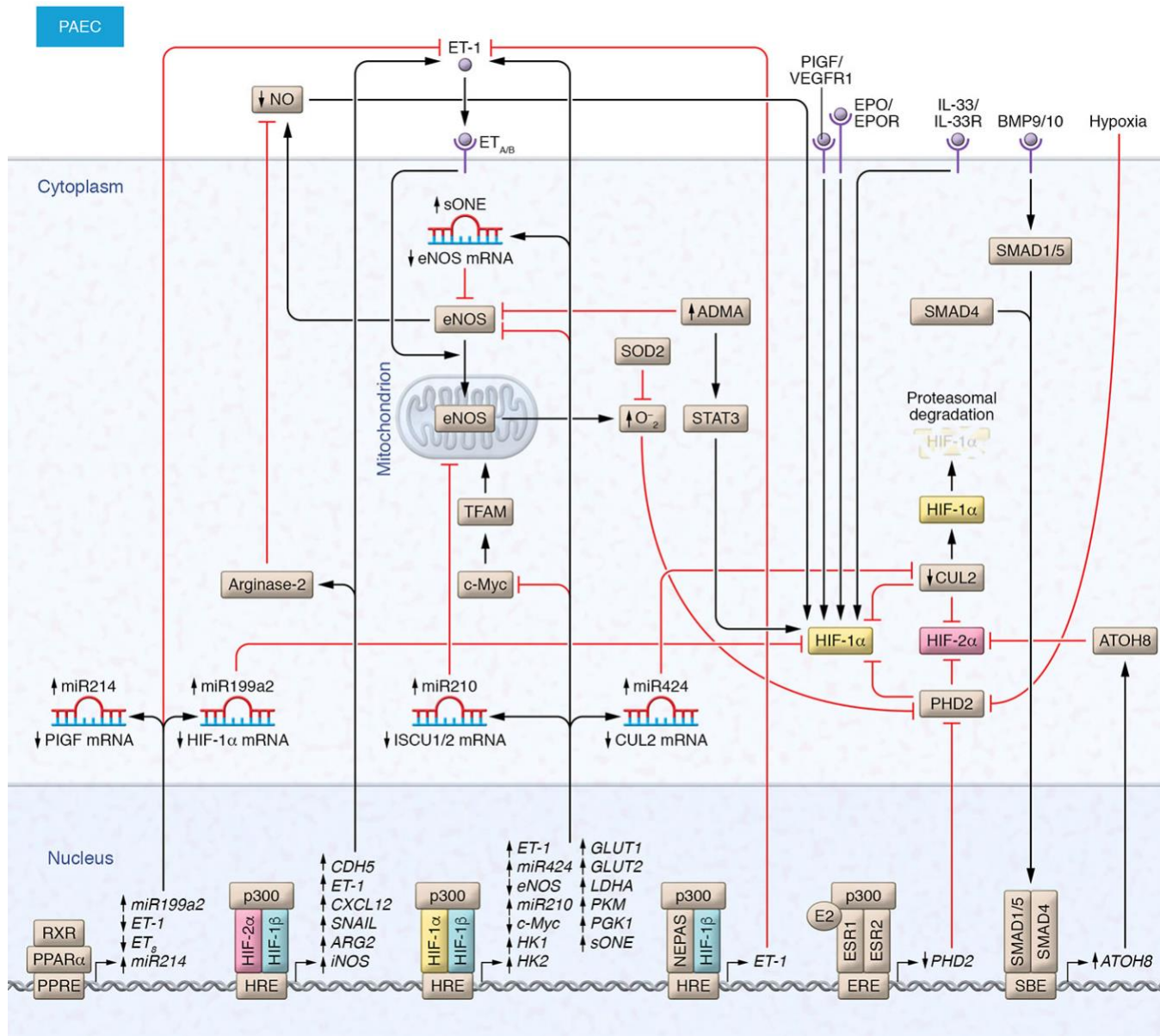

Figure 2. HIF signaling in PH: Upstream and downstream modulators in pulmonary artery endothelial cells. Vasomodulatory, mitochondrial, and inflammatory growth factors and epigenetic abnormalities associated with PH regulate HIF isoform stability and transcriptional activity in PAECs. Subsequently, HIF isoforms transcriptionally activate a series of genes that participate in vascular tone, angiogenesis, metabolism, and cell proliferation. →, activating effect; --|, inhibiting effect; ↑, activation or upregulation; ↓ inactivation or downregulation; TFAM, mitochondrial transcription factor A; PlGF, placental growth factor; EPO, erythropoietin; EPOR, erythropoietin receptor; ET-1, endothelin 1; EtA/B, endothelin receptor type A and B; sONE, antisense mRNA; ADMA, asymmetric dimethylarginine; Cul3, Cullin 3; E2, estradiol; ERβ, estrogen receptor beta; ATOH8, Atonal BHLH transcription factor 8; ISCU1/2, iron-sulfur (Fe-S) cluster assembly proteins 1 and 2; HK1, hexokinase 1; HK2: hexokinase 2; GLUT1, glucose transporter 1; GLUT2, glucose transporter 2; LDHA, lactate dehydrogenase A; PGK 1, phosphoglycerate kinase 1; PKM, pyruvate kinase M.

Figure 3

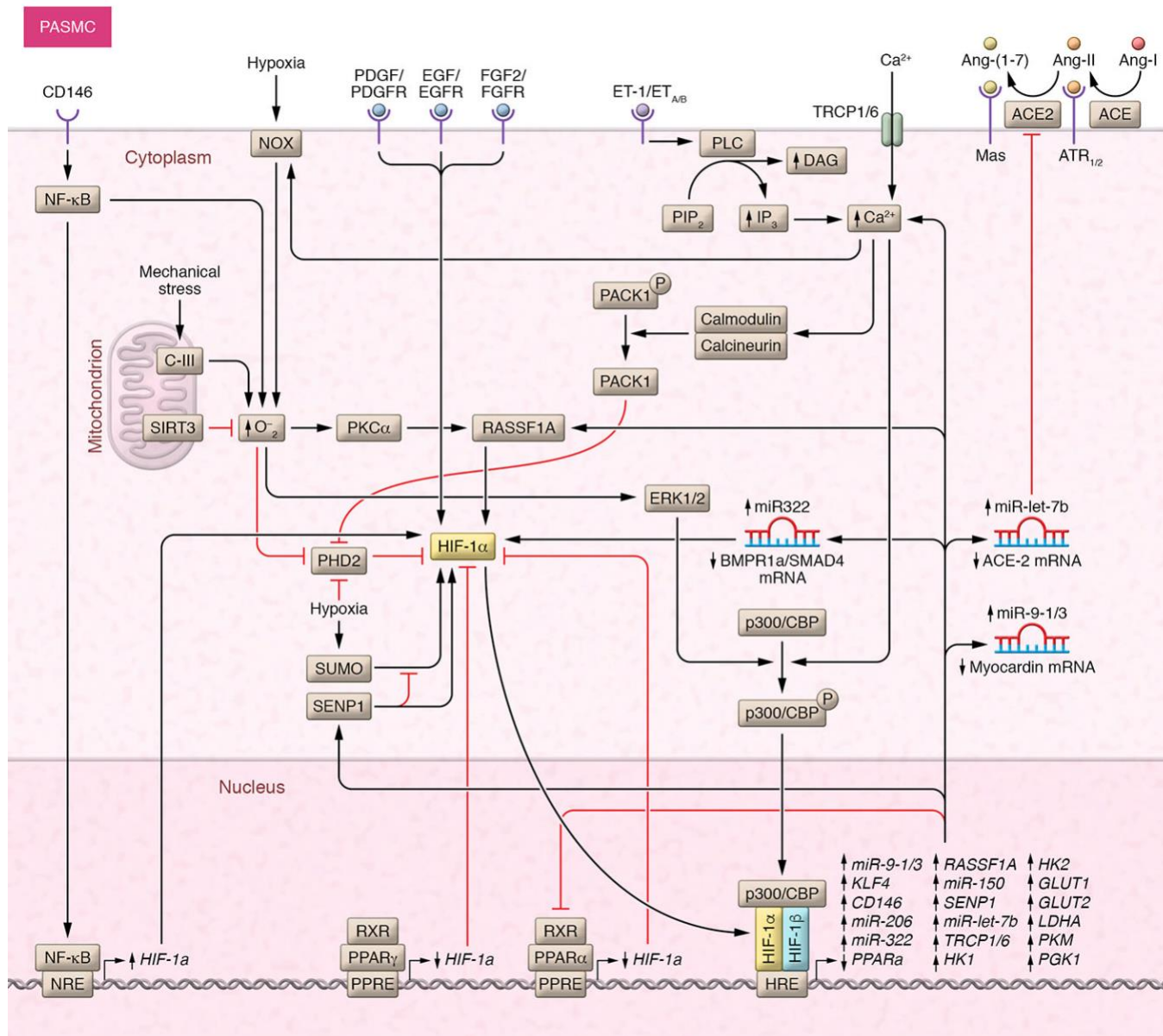

Figure 3. HIF signaling in PH: Upstream and downstream modulators in pulmonary artery smooth muscle cells. Signaling pathways associated with PH such as hypoxia, vasomodulation, growth factors, mechanical stress, and oxidative stress pathways regulate HIF isoform stability and transcriptional activity in PSMCs. This regulates genes related to cell proliferation and synthetic phenotypes, as well as genes related to Ca²⁺ modulation/ion channels, oxidative stress, mitochondrial fragmentation, and the renin-angiotensin-aldosterone system (RAAS) system. →, activating effect; —|, inhibiting effect; ↑, activation or upregulation; ↓ inactivation or downregulation; C-III, mitochondrial complex III; SIRT3, Sirtuin 3; TRPC6, transient receptor potential cation channel subfamily C member 1 or 6; FGFR, fibroblast growth factor receptor; ET-1, endothelin 1; ETA/B, endothelin receptor type A and B;; Ang-I, angiotensin I; Ang-II, angiotensin II; Ang-(1-7), angiotensin (1-7); Mas, Ang-(1-7) receptor; ATR1/2, angiotensin receptor type 1 and 2; ACE, angiotensin converting enzyme; ACE2, angiotensin converting enzyme 2; KLF4, krüppel-like factor 4; PIP2, phosphatidylinositol 4,5-bisphosphate; IP3, inositol trisphosphate; DAG, diacylglycerol; O₂⁻, superoxide anion; PKC α , protein kinase C alpha; RASSF1A, Ras association domain family 1A; PAK1, P21 activated kinase 1; SENP-1, sentrin-specific protease 1; HK1, hexokinase 1; HK2: hexokinase 2; GLUT1, glucose transporter 1; GLUT2, glucose transporter 2; LDHA, lactate dehydrogenase A; PGK 1, phosphoglycerate kinase 1; PKM, pyruvate kinase M.

Table 1. Summary of studies investigating upstream regulators of HIF signaling pathway in PH.

Upstream	Target	Cell type	Mechanisms	Effects implicated in cellular processes	Reference
miR-17/92	PHD2	PASMCs	miR17/92 targets 3' UTR of PHD2 mRNA		(141)
miR-322	HIF-1 α	PASMCs	miR-322 promotes HIF-1 α stability under hypoxia	miR-322 increases cell proliferation	(80)
miR-103/107	HIF-1 β	PASMCs	miR103/107 targets 3' UTR of HIF-1 β mRNA	Hypoxia induces miR103/107 downregulation leading to HIF-1 β upregulation resulting in increased cell proliferation	(142)
CD146	HIF-1 α	PASMCs	CD146 activates HIF-1 α expression through activation NF- κ B	CD146 mediates PASMCM proliferation, migration and enhances PASM synthetic markers (COL1A1, FN1, and VIM)	(143)
RASSF1A	HIF-1 α	PASMCs	ROS-mediated RASSF1A stabilization protects HIF-1 α from degradation and enhances its transcriptional activity	RASSF1A increases PASMCM proliferation and induces HIF-1 α -dependent glycolytic gene induction (PDK1, LDHA, and HK2) in PASMCs	(69)
Src	HIF-1 α	PASMCs	Phosphorylated src activates akt/mTOR signal pathway leading HIF-1 α protein stabilization	Src/Akt/mTOR signaling increases PASMCM proliferation and migration, decreases apoptosis	(144)
15-HETE	HIF-1 α	PASMCs	15-HETE increases both HIF-1 α expression and transcriptional activity	Inhibits PASMCM apoptosis	(145)
KLF5	HIF-1 α	PASMCs	KLF5 interacts with HIF-1 α protein to its stability under hypoxia	KLF5 stabilizes HIF-1 α protein leading to increases cell proliferation and migration and promotes cell apoptosis	(146)
PAK1	HIF-1 α	PASMCs	PAK1 activates HIF-1 α expression through NF- κ B signaling	Thrombin activated PAK1 leads to HIF-1 α expression resulting in increased ROS production and cell proliferation	(147)
SENP-1	HIF-1 α	PASMCs	SENP-1 induces deSUMOylation of HIF-1 α leading to its stability under hypoxia	SENP-1-mediated deSUMOylation of HIF-1 α leads to increased PASMCM proliferation in response to hypoxia	(62)
Pyk2	HIF-1 α	PASMCs	Hypoxia induced activation of Pyk2 leads to ROS-mediated HIF-1 α upregulation	Pyk2 promotes cell proliferation and migration under hypoxia	(148)
SUMO-1	HIF-1 α	PASMCs	SUMO-1 directly binds to HIF-1 α to induces its sumoylation resulting in its increased stability under hypoxia		(149)
ADMA	HIF-1 α	PAECs, PASMCs	ADMA stabilizes HIF-1 α through activating STAT3 signaling pathways	ADMA decreases eNOS expression, increases cytokine expression, cellular proliferation and calcium influx	(150)
S1P	HIF-1 α	PAECs, PASMCs	S1P leads to HIF-1 α stabilization independent of hypoxia	S1P induces HIF-1 α -dependent gene expressions	(151)
miR-199a2	HIF-1 α	PAECs	miR-199a2 targets 3' UTR of HIF-1 α mRNA	miR-199a2 downregulation leads to HIF-1 α -mediated ET-1 upregulation	(48)
ATOH8	HIF-2 α	PAECs	ATOH8 directly interacts with HIF-2 α to mediate its degradation	ATOH8 deficiency promotes HIF-2 α transcriptional activity with its target gene induction (DLL4 and ANGPT2) in PAECs	(53)
CPS1-IT	HIF-1 α	PAECs	CPS1-IT directly binds to HIF-1 α to reduce its transcriptional activity	Reduced CPS1-IT leads to NF- κ B-mediated IL-1 β expression through HIF-1 α activation	(152)
IRP1	HIF-1 α	PAECs	IRP1 binds to HIF-1 α mRNA IRE and prevents translation	IRP1 deletion leads to HIF-1 α protein expression resulting in HIF-1 α -dependent upregulation of ET-1	(153)
SOD2	HIF-1 α	PAECs	Converts superoxide to hydrogen peroxide and diatomic oxygen in the mitochondria	Attenuated SOD2 expression in PAECs leads to HIF-1 α stabilization	(21)
IL-33/ST2	HIF-1 α	PAECs	IL-33/ST2/HIF-1 α /VEGF signaling pathway promotes cell proliferation, adhesion and angiogenesis	IL-33/ST2/HIF-1 α /VEGF signaling pathway promotes cell proliferation, adhesion, and angiogenesis	(47)
Estradiol	HIF-1 α	PAECs	Estradiol receptor recruits Creb-binding protein (CBP)/p300, thereby limiting CBP/p300 availability to HIF-1 α	Estradiol attenuates hypoxia-induced ET-1 expression in PAECs	(51)
HIMF (FIZZ1/R ELMα)	HIF-1 α	Pulmonary fibroblasts	HIMF upregulates HIF-1 α through NF- κ B signaling	HIMF induces IL-6 in HIF-1 α -dependent manner	(154)

Table 2. Summary of studies evaluating the phenotypes of genetic manipulation of HIF and HIF regulators in animal models of PH

Gene	Disease model (time weeks)	Genotype	Tissue or cell/Gene deletion	RVP	PAR	RVR	Reference
<i>Hif1a</i>	HOX (5w)	Ubc ^{CreERT} -HIF1- α ^{F1/F1}	Global/Inducible (Tam)	↔	NA	↔	(155)
<i>Hif1a</i>	HOX (3w)	HIF-1 α ^{+/+}	Global/constitutive	↓	↓	↓	(98)
<i>Hif1a</i>	HOX (3w)	EC Alk1 ^{Cre} -HIF-1 α ^{F1/F1}	EC/constitutive	↔	↔	↔	(156)
<i>Hif1a</i>	HOX (3w)	EC Tie2 ^{CreERT2} -HIF-1 α ^{F1/F1}	EC/inducible (Tam)	↔	NA	↔	(28)
<i>Hif1a</i>	HOX (3w)	SMC SM22 ^{Cre} -HIF-1 α ^{F1/F1}	SMC/constitutive	↑	↔	NA	(157)
<i>Hif1a</i>	HOX (4w)	SMC Smm ^{CreERT2} -HIF-1 α ^{F1/F1}	SMC/Inducible (Tam)	↓	↓	↔	(158)
<i>Hif1a</i>	HOX (3w)	EC Cdh5 ^{CreERT2} -HIF-1 α ^{F1/F1}	EC/Inducible (Tam)	↓	NA	↓	(104)
<i>Hif1a</i>	HOX (3w)	Pdgfrb ^{CreERT2} -HIF-1 α ^{F1/F1}	MC/Inducible (Tam)	↓	NA	↓	(104)
<i>Hif1a</i>	HOX (3w)	Cx3cr1 ^{cre} -Hif-1 α ^{F1/F1}	Mono/constitutive	↓	↓	↓	(159)
<i>Hif1a</i>	HOX (3w)	LyzM ^{Cre} -Hif-1 α ^{F1/F1}	Myeloid cells	↓	↓	↓	(114)
<i>Hif1a/Hif2a</i>	Bleo (4w)	EC Cdh5 ^{Cre} -HIF-1 α /HIF-2 α ^{F1/F1}	EC/constitutive	↓	↓	↓	(106)
<i>Hif1a/Hif2a</i>	HOX (4w)	EC Cdh5 ^{Cre} -HIF-1 α /HIF-2 α ^{F1/F1}	EC/constitutive	↓	↓	↓	(106)
<i>Hif2a</i>	HOX (3w)	EC Alk1 ^{Cre} -HIF-2 α ^{F1/F1}	EC/constitutive	↓	↓	↓	(156)
<i>Hif2a</i>	HOX (4w)	HIF-2 α ^{+/+}	Global/constitutive	↓	↓	↓	(99)
<i>Hif2a</i>	HOX (4w)	HIF-2 α ^{+/+}	Global/constitutive	↓	NA	↓	(38)
<i>Hif2a</i>	HOX (4w)	HIF-2 α ^{+/+}	Global/constitutive	↓	NA	NA	(160)
<i>Hif2a</i>	HOX (4w)	EC Cdh5 ^{Cre} -HIF-2 α ^{F1/F1}	EC/constitutive	↓	↓	↓	(109)
<i>Hif2a</i>	HOX (3w)	EC Tie2 ^{CreERT2} -HIF-2 α ^{F1/F1}	EC/inducible (Tam)	↓	↓	↓	(28)
<i>Hif2a</i>	HOX (3w)	SMC SM ^{Cre} -HIF-2 α ^{F1/F1}	SMC/inducible (Tam)	↔	NA	↔	(28)
<i>Hif2a</i>	HOX (5w)	Global Ubc ^{CreERT} -HIF-2 α ^{Wt/F1}	Global/Inducible (Tam)	↔	NA	↓	(155)
<i>Hif2a</i>	HOX (4w)	EC Cdh5 ^{Cre} -HIF-2 α ^{F1/F1}	EC/constitutive	↓	↓	↓	(155)
<i>Hif2a</i>	4 – 6 month-old	EPAS1 ^{G536W/G536}	Global/constitutive	↑	↑	↑	(111)
<i>Hif2a</i>	3, 6 and 9 month-old	EC Cdh5 ^{Cre} -HIF-2 α ^{F1/F1}	EC/constitutive	↑	NA	↑	(105)
<i>Egln1 (Phd2)</i>	15-month-old	EC Cdh5 ^{Cre} -Egln1 ^{LoxP/LoxP}	EC/constitutive	↑	↑	↑	(110)
<i>Egln1</i>	10 – 12 week old	EC Cdh5 ^{Cre} -Egln1 ^{F1/F1}	EC/constitutive	↑	NA	↑	(109)
<i>Egln1</i>	3.5 month old	EC Tie2 ^{Cre} -Egln1 ^{F1/F1}	EC/constitutive	↑	NA	↑	(108)
<i>Egln1</i>	Spontaneous	EC Tie2 ^{Cre} -Egln1 ^{F1/F1}	EC/constitutive	↑	↑	↑	(28)
<i>Egln1</i>	HOX (4w)	SMC Smmh ^{CreERT2} -Egln1 ^{F1/F1}	SMC/inducible (Tam)	↔	↑	↓	(161)
<i>Egln1</i>	HOX (4w)	SMC Smmh ^{CreERT2} -Egln1 ^{F1/F1}	SMC/inducible (Tam)	↑	↔	↔	(161)
<i>Egln1</i>	HOX (3w)	Tibetan PHD2	Global	↔	NA	NA	(160)
<i>Nepas (Hif3a)</i>	Spontaneous	Global NEPAS/HIF-3 α ^{-/-}	Global/constitutive	↓	↑	↑	(46)
<i>Hif1a</i>	rHIMF	HIF-1 α ^{+/+}	Global/constitutive	↓	↓	↓	(162)
<i>Hif2a</i>	HOX (3w)	Th ^{CreERT2} -HIF-2 α ^{F1/F1}	CAC/constitutive	↑	↑	↔	(163)
<i>Hif2a</i>	HOX (3w)	Th ^{CreERT2} -HIF-1 α ^{F1/F1}	CAC/constitutive	↑	↔	↑	(163)

Abbreviations. ↑, significantly higher compared to wildtype counterparts; ↓, significantly lower compared to wildtype counterparts; ↔, no difference compared to wildtype counterparts; HOX, hypoxia; RVP, right ventricular systolic pressure; PAR, pulmonary artery remodeling; RVR, right ventricular remodeling; EC, endothelial cell; SMC, smooth muscle cell; MC, mesenchymal cell; Mono, monocyte; Tam, tamoxifen, CAC, catecholaminergic cells.

Table 3. Summary of studies evaluating the effects of pharmacological agents targeting HIF signaling in animal models of PH

Agent	Mechanism of action	Treatment option	Disease model	Agent application details	RVP	PA remodeling	RV remodeling	Reference
R59949	PHD2 activator	Therapeutic	HOX mice	Injection (i.p.) daily 5 days a week, 0.125 mg/25 g BW	↔	↓	↔	(161)
2-ME2	HIF-1 α inhibitor	Therapeutic	HOX rats	Implantation (s.c.), 60 μ g/kg per day	↓	↓	↓	(164)
Topotecan	HIF-1 α inhibitor	Preventive	HOX rats	Oral gavage daily, 1 mg/kg BW	↓	↓	↓	(165)
Topotecan	HIF-1 α inhibitor	Preventive	HOX rats	Oral gavage daily, 10 mg/kg BW	↓	↓	↓	(165)
Digoxin	HIF-1 α inhibitor	Preventive	HOX mice	Injection daily, 1.0 mg/kg BW	↓	NA	↓	(166)
anti-CD146 mAb AA98	HIF-1 α inhibitor	Therapeutic	HOX mice	Injection (i.p.) twice a week, 5 mg/kg BW	↓	↓	↓	(55)
anti-CD146 mAb AA98	HIF-1 α inhibitor	Therapeutic	MCT rats	Injection (i.p.) twice a week, 5 mg/BW	↓	↓	↓	(55)
CAPE	HIF-1 α inhibitor	Therapeutic	MCT rats	Injection (i.p.) daily, 5 or 10 mg/kg BW	↓	↓	↓	(167)
Celastramycin	HIF-1 α inhibitor	Preventive	HOX mice	Osmotic pump, 10 mg/kg BW	↓	↓	↓	(168)
Celastramycin	HIF-1 α inhibitor	Preventive	MCT rats	Injection (s.c.) daily, 3 mg/kg BW	↓	↓	↓	(168)
Celastramycin	HIF-1 α inhibitor	Therapeutic	SuHx rats	Injection (s.c.) daily, 3 mg/kg BW	↓	↓	↓	(168)
YC-1	HIF-1 α inhibitor	Preventive	HOX mice	Injection (i.p.) daily, 5 mg/kg BW	↓	↓	↓	(169)
YC-1	HIF-1 α inhibitor	Therapeutic	HOX mice	Injection (i.p.) daily, 5 mg/kg BW	↓	↓	↓	(169)
HIF2 α -ASO	HIF-2 α inhibitor	Preventive	HOX mice	Injection (i.p.) twice a week, 50mg/kg BW	↓	↓	↓	(155)
PT2567	HIF-2 α inhibitor	Preventive	HOX rats	Oral gavage daily, 300 mg/kg BW	↓	↓	↓	(155)
C76	HIF-2 α inhibitor	Preventive	EC Phd2 KO mice	Injection (i.p.) daily, 12.5 mg/kg BW	↓	↓	↓	(27)
C76	HIF-2 α inhibitor	Therapeutic	SuHx rats	Injection (i.p.) daily, 12.5 mg/kg BW	↓	↓	↓	(27)
C76	HIF2 α inhibitor	Therapeutic	MCT rats	Injection (i.p.) daily, 12.5 mg/kg BW	↓	↓	↓	(27)
apigenin	HIF-1 α inhibitor	Preventive	HOX rats	Oral gavage, daily, 50 mg/kg BW or 160 mg/kg BW	↓	↓	↓	(170)
apigenin	HIF-1 α inhibitor	Therapeutic	HOX rats	Oral gavage, daily, 50 mg/kg BW or 160 mg/kg BW	↓	↓	↓	(170)

Abbreviations. \uparrow , significantly higher compared to placebo treated counterparts; \downarrow , significantly lower compared to placebo treated counterparts; \leftrightarrow , no difference compared to placebo treated counterparts; HOX, hypoxia; SMC, smooth muscle cell; EC, endothelial cell; RVSP, right ventricular systolic pressure; RV/(LV+S), right ventricular mass divided by left ventricular mass plus septal mass; WT, pulmonary artery wall thickness; PAAT, pulmonary artery acceleration time; ET, ejection time; RV FAC, right ventricular fractional change; RVWT, right ventricular wall thickness; RV/BW, right ventricular mass divided by body weight; RVD, right ventricular diameter; TAPSE, tricuspid annulus plane systolic excursion; RV SV, right ventricular stroke volume.