

**Dissection of antigenic and irritative effects of epicutaneously applied haptens in mice. Evidence that not the antigenic component but nonspecific proinflammatory effects of haptens determine the concentration-dependent elicitation of allergic contact dermatitis.**

S Grabbe, ... , T A Luger, T Schwarz

*J Clin Invest.* 1996;**98**(5):1158-1164. <https://doi.org/10.1172/JCI118899>.

**Research Article**

Allergic contact dermatitis differs from most other immune reactions by its strict dose dependence during the elicitation phase. Moreover, almost all known contact allergens can also induce dose-dependent irritative dermatitis and in general only elicit allergic contact dermatitis in sensitized individuals when applied within a narrow dose range. Therefore, we hypothesized that elicitation of contact hypersensitivity (CHS) may require two signals, antigen-specific effector cell activation and a non-antigen-specific proinflammatory signal, both of which are provided by application of a sufficient dose of hapten. To dissociate these putative two signals, oxazolone-sensitized mice were ear challenged with a dose of the specific hapten which was too low to elicit CHS. At the same time, an unrelated hapten was applied in a conventional concentration to the same skin site. Whereas neither treatment alone elicited a significant CHS response, application of both compounds together resulted in a strong CHS response that was indistinguishable from that elicited by the full dose of the specific hapten. Upon coadministration of the irrelevant hapten, allergic contact dermatitis could be elicited even when the dose of the specific hapten was further reduced by a factor of 10(3). In contrast, a dose reduction of the irrelevant hapten by a factor of two resulted in the loss of the CRS response. These data indicate that non-antigen-specific effects of epicutaneously applied haptens [...]

**Find the latest version:**

<https://jci.me/118899/pdf>



# Dissection of Antigenic and Irritative Effects of Epicutaneously Applied Haptens in Mice

## Evidence That Not the Antigenic Component but Nonspecific Proinflammatory Effects of Haptens Determine the Concentration-dependent Elicitation of Allergic Contact Dermatitis

Stephan Grabbe, Meike Steinert, Karsten Mahnke, Agatha Schwarz, Thomas A. Luger, and Thomas Schwarz

Ludwig Boltzmann Institute for Cell Biology and Immunobiology of the Skin, Department of Dermatology, University of Münster, D-48149 Münster, Germany

### Abstract

Allergic contact dermatitis differs from most other immune reactions by its strict dose dependence during the elicitation phase. Moreover, almost all known contact allergens can also induce dose-dependent irritative dermatitis and in general only elicit allergic contact dermatitis in sensitized individuals when applied within a narrow dose range. Therefore, we hypothesized that elicitation of contact hypersensitivity (CHS) may require two signals, antigen-specific effector cell activation and a non-antigen-specific proinflammatory signal, both of which are provided by application of a sufficient dose of hapten. To dissociate these putative two signals, oxazolone-sensitized mice were ear challenged with a dose of the specific hapten which was too low to elicit CHS. At the same time, an unrelated hapten was applied in a conventional concentration to the same skin site. Whereas neither treatment alone elicited a significant CHS response, application of both compounds together resulted in a strong CHS response that was indistinguishable from that elicited by the full dose of the specific hapten. Upon coadministration of the irrelevant hapten, allergic contact dermatitis could be elicited even when the dose of the specific hapten was further reduced by a factor of  $10^3$ . In contrast, a dose reduction of the irrelevant hapten by a factor of two resulted in the loss of the CHS response. These data indicate that non-antigen-specific effects of epicutaneously applied haptens significantly contribute to the elicitation of CHS responses and that the capacity of the hapten to evoke this proinflammatory stimulus rather than its antigenicity is responsible for the strict concentration dependence. (*J. Clin. Invest.* 1996; 98:1158–1164.) Key words: contact hypersensitivity • allergic contact dermatitis • irritant dermatitis • contact sensitizers • mouse

### Introduction

Contact hypersensitivity (CHS)<sup>1</sup> is both a relevant clinical disorder in industrialized countries and a common experimental model for investigation of antigen (Ag)-specific, T cell-mediated immune responses. Most contact allergens are haptens, small molecular weight molecules that bind to host proteins to form a complete allergen. Epicutaneous application of haptens in mice is a widely used test system for cell-mediated immune responses in general. However, there are several features that distinguish CHS from other delayed-type hypersensitivity (DTH) responses: (a) CHS and DTH responses differ significantly with regard to their modulation by glucocorticoids or ultraviolet (UV) irradiation (1, 2). (b) Indirect evidence suggests that CD4<sup>+</sup> T cells may not be the principal CHS effector cell type, and that MHC class II<sup>+</sup> epidermal Langerhans cells (LC) may not be required for elicitation of CHS (2, 3). Both findings suggest that during elicitation of CHS, Ag is neither presented primarily in the context of MHC class II nor that CD4<sup>+</sup> effector T cells are the principal cell type eliciting CHS responses. Thus, CHS appears to differ significantly from other types of cell-mediated immune responses, e.g., DTH responses to infectious agents, alloantigens, neoplasms, or subcutaneously applied hapten-coupled Ag-presenting cells (1, 4). (c) Almost all known haptens also elicit significant irritative dermatitis, when applied even at only slightly supraoptimal doses (5). (d) Relatively large amounts of hapten are required for elicitation of CHS, whereas most other Ag-specific immune responses in general only require minute amounts of Ag without a rigid dose dependence after passing a threshold dose. In contrast, elicitation of allergic contact dermatitis is characterized by an obvious dose dependence. (e) Clinical experience shows that in most cases contact allergens do not elicit a DTH response when injected subcutaneously into sensitized individuals (5). Therefore, we wondered whether haptens, in addition to their antigenic properties, also act as “irritants” and provide a proinflammatory stimulus upon epicutaneous application, which conditions the tissue for full CHS elicitation. Consequently, we hypothesized that haptens may exhibit nonspecific proinflammatory effects which facilitate or enable the development of a visible hapten-specific immune response, and that these nonspecific effects could be responsible for the relatively high doses of hapten required for elicitation of allergic contact dermatitis. To test this hypothesis, mice were sensitized with the

---

Address correspondence to Dr. Stephan Grabbe, Department of Dermatology, University of Münster, Von-Esmarch-Str. 56, D-48149 Münster, Germany. Phone: 49-251-83 6582; FAX: 49-251-83 8579; E-mail: Grabbe@uni-muenster.de.

Received for publication 14 December 1995 and accepted in revised form 9 July 1996.

---

*J. Clin. Invest.*

© The American Society for Clinical Investigation, Inc.

0021-9738/96/09/1158/07 \$2.00

Volume 98, Number 5, September 1996, 1158–1164

---

1. Abbreviations used in this paper: Ag, antigen; CHS, contact hypersensitivity; DTH, delayed-type hypersensitivity; LC, Langerhans cell; MIP, macrophage inflammatory protein; OXA, oxazolone; TNCB, trinitrochlorobenzene; UVB, ultraviolet radiation B.

haptens trinitrochlorobenzene (TNCB) or oxazolone (OXA) and challenged with a dose of the specific Ag which was too low to elicit an ear swelling response in sensitized animals. Together with the specific hapten, an irrelevant hapten was applied at the same time and used in a dose that usually elicits a strong CHS response in sensitized mice, but which has no effect in naive animals. Whereas sensitized mice challenged with either the specific Ag in a low dose or with the irrelevant Ag in a high dose alone did not show a significant ear swelling response, mice challenged with both together developed a strong CHS response that was indistinguishable from that elicited by the full dose of the specific Ag. Moreover, the dose of the specific Ag could be titrated down  $> 3$  logs and was still capable of eliciting a significant CHS response, provided an irrelevant hapten was administered at the same time. These data indicate that non-Ag-specific effects of epicutaneously applied haptens significantly contribute to the elicitation of CHS responses to these haptens and may be primarily responsible for the concentration dependence of the effector phase of CHS.

## Methods

**Mice.** 6–12-wk-old BALB/c or C3H/HeN mice of both sexes were obtained from Charles River (Sulzbach, Germany) and housed according to federal regulations.

**Reagents.** The following haptens and irritants were used: TNCB (Kodak, Rochester, NY), its water-soluble analogue, trinitrobenzenesulfonic acid (Sigma, St. Louis, MO), OXA (Sigma), benzalkonium chloride (Sigma), and croton oil (Serva, Heidelberg, Germany). Cytokines used in this study include IL-1 $\alpha$ , IL-1 $\beta$ , macrophage inflammatory protein (MIP)-1 $\alpha$ , TNF $\alpha$  (all from Genzyme, Cambridge, MA), GM-CSF (Biosource, Camarillo, CA), and IL-12 (kindly provided by Dr. S. Wolf, Genetics Institute, Cambridge, MA).

**CHS and irritant dermatitis.** CHS experiments were performed as described previously (2, 6). Briefly, mice were sensitized by painting 100  $\mu$ l of 0.15% TNCB or 50  $\mu$ l of 2% OXA in acetone:olive oil 4:1 on the shaved abdomen of naive mice. For elicitation of CHS, ears of mice were painted with 10  $\mu$ l of 0.8% TNCB and 0.5% OXA, respectively, on one ear. CHS was determined by the degree of ear swelling

of the hapten-exposed ear compared with the vehicle-treated contralateral ear and measured with a spring-loaded caliper (Oditest, Kroeplin, Schüchter, Germany) 24 or 36 h after challenge. Mice that were ear challenged without prior sensitization served as negative controls. For induction of irritant dermatitis, 10  $\mu$ l of 0.8% croton oil or 10  $\mu$ l of 5% benzalkonium chloride in acetone was painted on one ear of naive mice. As a measure of irritant dermatitis, ear swelling was determined 16 and 24 h later, using a spring-loaded caliper. In some experiments, different cytokines were dissolved in PBS containing 0.1% mouse serum. 25  $\mu$ l was injected subcutaneously into one ear using a 30 gauge needle 10 min before hapten challenge.

**UV irradiation and induction of hapten-specific tolerance.** UV irradiation was performed according to a standard protocol (7, 8). Since only certain mouse strains can be effectively tolerized by low-dose ultraviolet radiation B (UVB), C3H/HeN mice were used for these experiments. The shaved backs of C3H/HeN mice were exposed to UV light from a bank of four FS-20 fluorescent lamps (Westinghouse Electric Corp., Pittsburgh, PA) which emit most of their energy within the UVB range (290–320 nm) with an emission peak at 313 nm. The UV output measured at 310 nm using an IL1700 research radiometer (International Light, Newport, MA) was 8.0 W/m<sup>2</sup> at a tube to target distance of 28 cm. Mice were exposed to UVB daily for four consecutive days on the back (1,000 J/m<sup>2</sup> per exposure). 48 h after the last UV exposure 50  $\mu$ l of 0.5% TNCB was applied to the irradiated skin area as described above. 14 d later, mice were sensitized to OXA as described above, or resensitized to TNCB through abdominal skin to verify tolerance induction. 6 d after the second sensitization, all mice were challenged with either optimal challenge doses of TNCB (0.8%) or OXA (0.5%), or with low-dose OXA (0.05%) in combination with TNCB. CHS was determined 24 or 36 h after challenge as described above.

**Data generation and statistical evaluation.** In each individual experiment, between four and seven mice were used per group. Key experiments were performed at least three times, data shown are obtained from one representative experiment. Data were analyzed using the Student's *t* test for independent samples.

## Results

**Dose-response relations of haptens in sensitized and naive mice.** The specificity of CHS response is generally defined as the dif-

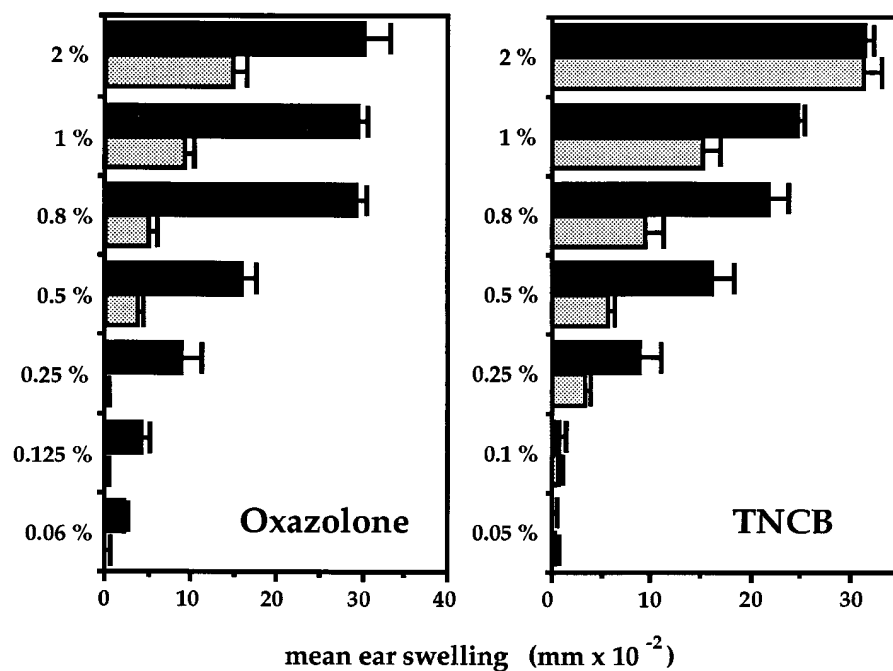

**Figure 1.** Dose dependence of hapten-specific CHS responses. Ears of TNCB- or OXA-sensitized (black bars) BALB/c mice and of naive (shaded bars) control animals, respectively, were challenged with the respective hapten in various concentrations ( $n = 6$  mice per group). Ear swelling was determined as the difference between the challenged and the vehicle-treated contralateral ear. Data (from a representative experiment) show mean ear swelling responses after 24 h  $\pm$  SEM.

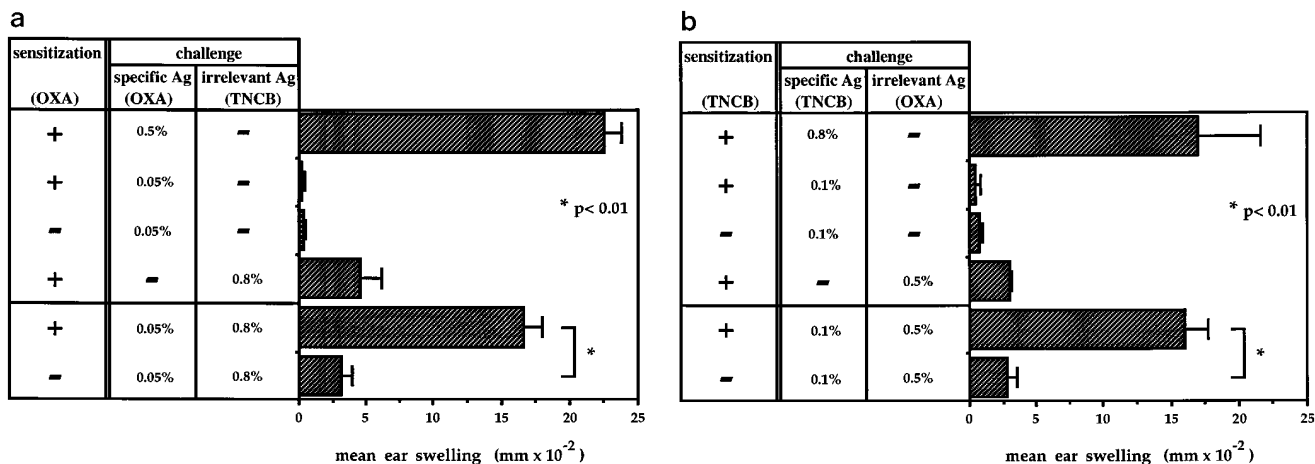

Figure 2. Application of irrelevant hapten enables CHS response to an insufficient dose of specific hapten. Ears of OXA (a) or TNCB (b)-sensitized BALB/c mice, or of naive control animals, were challenged with either a regular dose of the specific hapten, a low dose of specific hapten (insufficient to elicit a specific response), or with a low dose of specific hapten plus an irrelevant hapten. 24 h later, ear swelling was determined as the difference between the challenged and the vehicle-treated contralateral ear (mean  $\pm$  SEM). Data are from a representative experiment ( $n = 5$  mice per group). Whereas low-dose hapten alone did not induce significant CHS, combined application of low-dose specific hapten plus irrelevant hapten resulted in pronounced ear swelling in sensitized but not in naive mice.

ference between ear swelling responses to a given hapten dose in naive versus sensitized animals. However, as shown in Fig. 1, the haptens OXA and TNCB exhibit strict dose-response dependencies both in sensitized as well as in naive animals. Of note, topical application of these haptens results in significant ear swelling responses in naive mice when given at doses only twice the optimal dose for elicitation of CHS, and doses only one decade lower than the optimal challenge dose fail to elicit CHS even in sensitized mice.

*CHS response to low amounts of specific hapten insufficient to elicit CHS is reconstituted by application of irrelevant hapten.* Due to the tight-dose response of CHS and the significant irritative potential of haptens, we hypothesized that elicitation of CHS may require two signals, Ag-specific effector cell activation and a non-Ag-specific proinflammatory signal, both of which are provided by application of a sufficient dose of hapten. To dissociate these putative two signals, OXA-sensitized mice were ear challenged with a dose of the specific hapten which is insufficient to elicit CHS. At the same time, an unrelated hapten was applied to the same skin site (which on its own also did not elicit significant CHS, since mice were not sensitized to this hapten.) As shown in Fig. 2 a, application of both compounds together resulted in a significant ear swelling response in sensitized animals that was indistinguishable from the response to the optimal dose of the relevant hapten alone. This ear swelling response was not due to toxic effects of the combined application of both compounds, since no reaction was observed in naive mice. Moreover, neither the low dose of the specific hapten (OXA) nor the irrelevant hapten (TNCB) alone elicited a significant ear swelling response in naive or OXA-sensitized animals. Thus, application of an irrelevant hapten completely restored the CHS response to a dose of the specific hapten that is incapable of eliciting CHS in sensitized mice when applied without further stimuli. Fig. 2 b demonstrates that the same result can also be obtained by exchanging the specific and irrelevant hapten, indicating that this effect is not restricted to OXA. The observed effect is not due to cross-reactivity between OXA and TNCB, since a specific CHS re-

sponse could only be elicited in mice sensitized to the specific hapten (data not shown).

*The nonspecific, proinflammatory capacity of hapten rather than its antigenic property determines the dose dependence of hapten-specific CHS.* The above-mentioned results suggested that a low amount of specific hapten is sufficient to elicit hapten-specific CHS, provided that a non-Ag-specific proinflammatory stimulus was administered at the same time. To test whether the concentration of specific hapten or the intensity of the non-Ag-specific stimulus is the limiting factor responsible for the tight dose dependence of hapten-specific CHS, titration curves for the specific hapten and the irrelevant hapten were performed. Fig. 3 a indicates that the hapten-specific CHS, as defined by the difference in ear swelling between sensitized and naive animals, is rapidly lost upon reduction of the concentration of the irrelevant hapten (TNCB). On the other hand, the concentration of the specific hapten (OXA) could be reduced by a factor of  $> 10^3$  while maintaining significant differences in ear swelling intensity between sensitized and naive mice (Fig. 3 b). These data indicate that allergen concentration is not the limiting factor for elicitation of CHS. Instead, it appears that the non-Ag-specific, proinflammatory stimulus, which is also provided by hapten application, is highly dose dependent and determines whether CHS will develop or not.

*The synergistic effect of unrelated hapten is nonimmunologic in nature.* Since all haptens in this study are obligatory sensitizers, the application of unrelated hapten during CHS elicitation results in the induction of a specific immune response toward the unrelated hapten. Therefore, it appears possible that the observed synergism between the unrelated hapten and low-dose specific hapten in elicitation of CHS is mediated by immune recognition of the unrelated hapten. To test this hypothesis, mice were tolerized to TNCB by hapten application to UV-exposed skin according to a standard protocol (7, 8). This treatment consistently results in hapten-specific tolerance, as UVB-irradiated mice exhibit suppression of CHS even after additional sensitization at unirradiated skin sites (7, 8). To determine whether tolerization against TNCB alters its

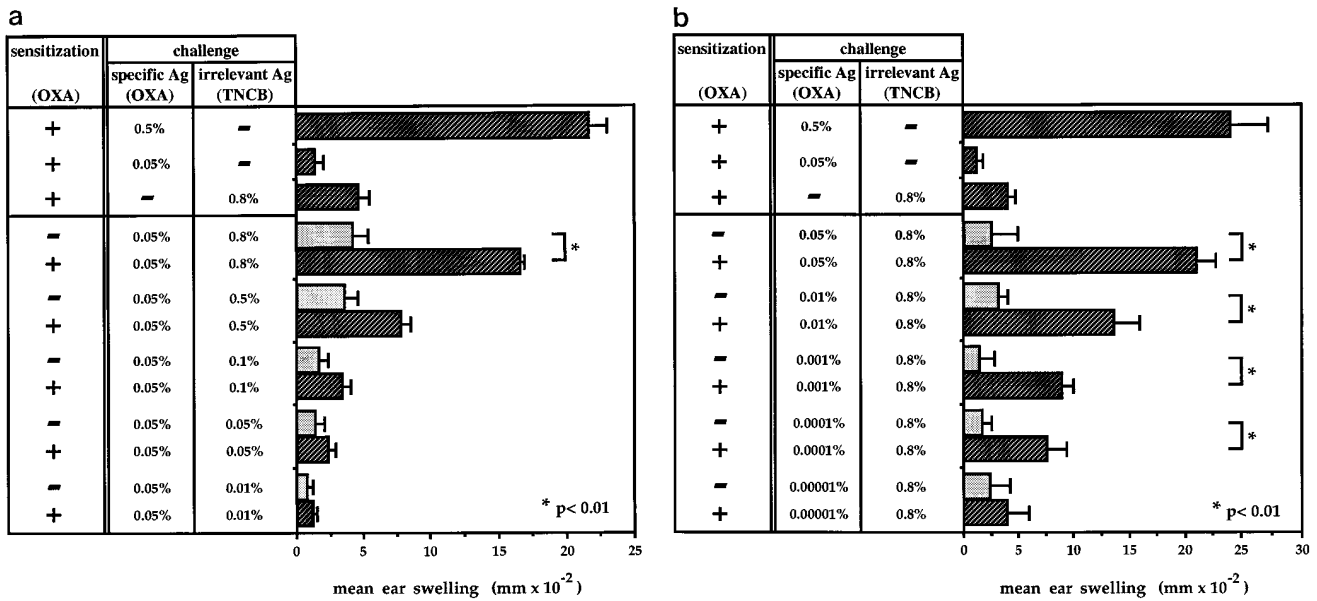

**Figure 3.** Titration of specific and irrelevant hapten. Ears of OXA-sensitized BALB/c mice, or of naive control animals, were challenged with either a low dose of the specific hapten (OXA) plus graded doses of an irrelevant hapten (TNCB) (a), or with a fixed dose of irrelevant hapten plus graded doses of specific hapten (b). 24 h later, ear swelling was determined as the difference between the challenged and the vehicle-treated contralateral ear (mean  $\pm$  SEM). Data are from a representative experiment ( $n = 5$  mice per group). Whereas reduction of the irrelevant hapten to half of the optimal challenge dose results in loss of significant allergic contact dermatitis (as defined by the difference in ear swelling response between sensitized and naive mice), reduction of the dose of specific hapten to  $< 0.1\%$  of the optimal challenge dose still produces a significant CHS response.

synergistic effect on elicitation of CHS to low-dose OXA, a group of TNCB-tolerized mice was subsequently OXA-sensitized at unirradiated skin sites and challenged with a combination of low-dose OXA and a conventional dose of TNCB (Fig. 4, group 10). Control mice received the same treatment, but without prior tolerization to TNCB (Fig. 4, group 9). Groups 3–5 in Fig. 4 verify TNCB-specific suppression of CHS and tolerance induction by UVB. Thus, tolerization to TNCB did not alter the synergistic effect of TNCB on elicitation of CHS to low-dose OXA, indicating that the effect of the unrelated hapten is not due to an immune-mediated mechanism.

*Irritants and several exogenously applied cytokines are incapable of providing the proinflammatory stimulus required for elicitation of CHS.* To investigate whether the non-Ag-specific, proinflammatory stimulus is specific for haptens as a group, or whether other compounds such as irritants would also be able to provide this stimulus, we applied a low dose of specific hapten together with a small amount of irritant (croton oil). Both substances were administered at doses that on their own are insufficient to elicit significant contact or irritative dermatitis. As demonstrated in Fig. 5 a, ear challenge with low-dose irritant plus low-dose specific hapten resulted in an ear swelling response that was only slightly larger than that of either component alone. However, a hapten-specific immune response was detectable to some extent, since the same treatment in naive mice led to a significantly smaller ear swelling response. Similarly, no additive or synergistic effect was observed when TNCB-sensitized mice were challenged with a low dose of TNCB plus an intermediate dose of irritant, which already elicited a mild inflammatory response on its own (Fig. 5 b). Although the combination of low-dose OXA plus irritant induced a stronger ear swelling response than OXA alone, this

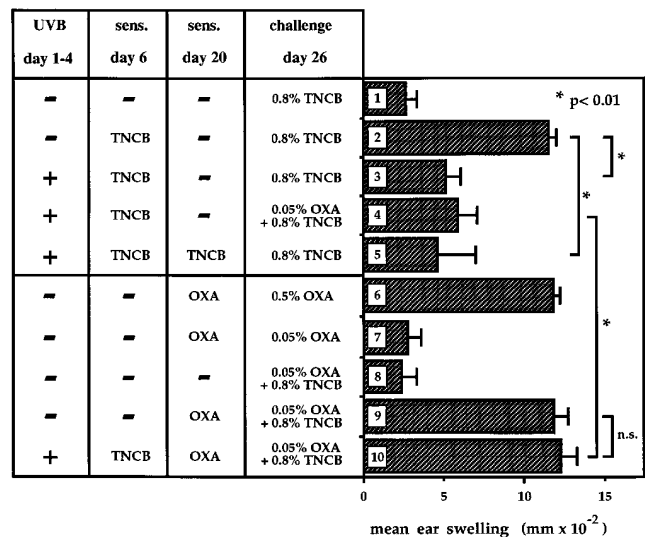

**Figure 4.** The effect of the unrelated hapten is nonimmunologic in nature. Ears of OXA- or TNCB-sensitized C3H/HeN mice, or of naive control animals, were challenged with either a low or a conventional dose of the specific hapten (OXA) and/or a conventional dose of the unrelated hapten (TNCB). Some groups of mice (groups 3, 4, 5, 10) were tolerized to TNCB by prior application of TNCB to UV-irradiated back skin as described in Methods. 24 h after hapten application, ear swelling was determined as the difference between the challenged and the vehicle-treated contralateral ear (mean  $\pm$  SEM).  $n = 5$ –6 mice per group.

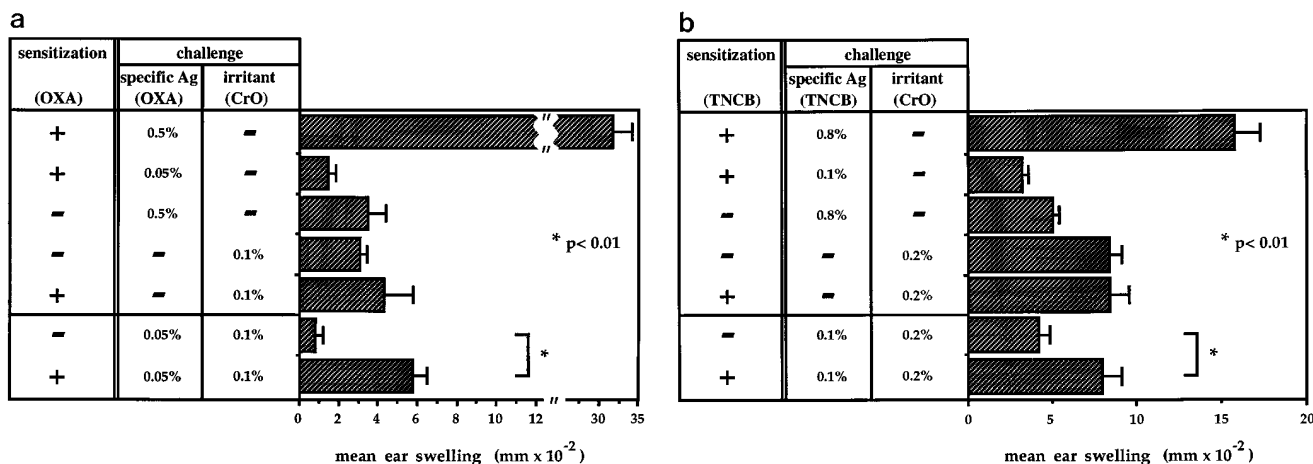

Figure 5. Irritants do not potential CHS to low doses of hapten. Ears of OXA- (a) or TNCB (b)-sensitized BALB/c mice, or of naive control animals, were challenged with either a low dose of the specific hapten (OXA) plus a low dose of irritant (croton oil, *CrO*) (a), or with a low dose of the specific hapten ((TNCB) plus an intermediate dose of irritant (b). Low dose of irritant was defined as a dose that on its own was unable to elicit significant irritant dermatitis. Intermediate dose of irritant was defined as a dose that elicited mild but statistically significant irritant dermatitis. 24 h later, ear swelling was determined as the difference between the challenged and the vehicle-treated contralateral ear (mean  $\pm$  SEM). In both cases, coadministration of irritant enhanced the ear swelling response to low-dose specific hapten somewhat (compared with naive control animals), but did not induce profound CHS response, when compared with the optimal challenge dose of the specific hapten.

effect may be attributed to the irritant itself, since application of croton oil alone to sensitized or naive mice resulted in a similar response. Other irritants such as benzalkonium chloride or sodium-laurylsulfate also did not synergize with low-dose hapten to elicit CHS (data not shown). These data suggest that irritants at doses that do not result in significant skin inflammation are not capable of providing a signal required for elicitation of CHS in the presence of low-dose hapten. Since higher concentrations of irritant elicit potent ear swelling responses on their own, it is not possible to determine by this method whether larger doses of irritants affect elicitation of hapten-specific CHS.

To further characterize the nature of the non-hapten specific, proinflammatory component that appears to be required for elicitation, we again applied a low dose of specific hapten to ears of sensitized and naive mice, and in addition injected these ears with low doses of several cytokines known to be involved in Ag-specific cutaneous immune responses. Preliminary experiments revealed that intradermal injection of most of the cytokines of interest evoked an inflammatory reaction above a certain dose. To test the effects of these cytokines on CHS elicitation, we therefore had to use cytokine doses that were not proinflammatory when used without any additional hapten application. Subcutaneous injection of neither IL-1 $\alpha$  (50–100 U in 25  $\mu$ l PBS, injected subcutaneously into one ear 10 min before hapten challenge), IL-12 (25–100 ng), TNF $\alpha$  (100 U), GM-CSF (250 U), nor of MIP-1 $\alpha$  (100 ng) resulted in enhanced ear swelling response to low-dose hapten, although some of these cytokines evoked a nonspecific inflammatory response and enhanced both allergic and irritant dermatitis (data not shown). In two of five experiments, injection of 100 U IL-1 $\beta$  into ears, followed by low-dose hapten challenge, resulted in a significant ear swelling response in sensitized but not in naive mice. In these experiments, the same amount of IL-1 $\beta$  did not affect the ear swelling response to a low dose of irritant (data not shown). However, this effect was not consistently reproducible, since in three other experiments no selective effect of

IL-1 $\beta$  on elicitation of CHS could be observed in this system. Moreover, in only one of these experiments, IL-1 $\beta$  injection resulted in a > 50% reconstitution of CHS response, whereas in all other experiments only marginal or no specific effects were seen. Therefore, we conclude that none of the cytokines tested under these conditions was consistently able to substitute the appropriate non-hapten-specific proinflammatory stimulus required for elicitation of CHS in this system.

## Discussion

Although allergic contact dermatitis is a classical T cell-mediated, Ag-specific immune response, its pathophysiology is still not well understood, especially with regard to the elicitation phase of this reaction. Moreover, the clinical manifestation of allergic contact dermatitis is often surprisingly variable. Exposure to contact allergens does not always result in dermatitis reactions in sensitized patients universally, and sometimes particular skin areas are not affected despite contact with the respective allergen (5). Moreover, in vitro and in vivo allergen tests exhibit only limited reproducibility and correlation to clinical symptoms. This suggests that other factors besides the specific allergen itself are necessary for a full CHS response. In addition, it is sometimes difficult to clearly differentiate allergic and irritant contact dermatitis. Not only the clinical picture but also the histopathology and immunohistology of both conditions can be virtually indistinguishable, and even experimental test systems such as the local lymph node assay were found to be incapable of differentiating irritants from allergens (9–11). Thus, despite the very different immunological mechanisms underlying CHS and irritant dermatitis, it appears that these conditions have at least partially overlapping pathophysiology. Moreover, it is well established that most haptens also exhibit dose-dependent cutaneous toxicity and thus can act as irritants (5). Therefore, we hypothesized that this irritative potential of haptens may be of pathophysiological significance for their capacity to elicit immune-mediated CHS responses. Our data

demonstrate that elicitation of CHS indeed requires some form of irritative, proinflammatory stimulus, since coadministration of irrelevant hapten with a low dose of specific hapten in sensitized mice yielded a full CHS response, whereas application of either substance alone failed to elicit a significant reaction. This CHS response is specific because the identical combination of haptens failed to induce ear swelling in non-sensitized animals. Titration studies clearly showed that reduction of the dose of the specific hapten by a factor of  $10^3$  still induces a significant allergic contact dermatitis, provided that an irrelevant hapten is applied at the same site. In contrast, reduction of the irrelevant hapten only by a factor of two results in a loss of specific immune response despite coadministration of the low dose of relevant hapten. This clearly suggests that the capacity of a hapten to evoke this proinflammatory stimulus rather than its antigenicity is responsible for the strict concentration dependence during elicitation of a CHS response.

To further confirm that the effect of the unrelated hapten is due to non-immune-mediated mechanisms rather than to its inherent immunogenicity, experiments were performed in mice tolerized against the unrelated hapten. For this purpose, we used the model of UV-induced tolerance, which has been shown to result in active downregulation of hapten-specific immune responses and in generation of hapten-specific suppressor cells (7, 8). Since tolerization against the unrelated hapten did not affect its effectiveness in this system, these data suggest that the synergism of the unrelated hapten with low-dose specific hapten for CHS elicitation is not due to specific immune recognition of the second hapten. Although UVB irradiation is a well-characterized and reliable model for tolerance induction, the data obtained have to be interpreted with some caution, since a residual hapten-specific response was detectable even in tolerized mice, which might have affected the readout system (Fig. 4, groups 3–5).

However, the exact nature of the proinflammatory stimulus has not yet been defined. Nevertheless, this signal appears to be somewhat restricted to haptens, since subinflammatory doses of the irritants croton oil or benzalkonium chloride were unable to substitute for the effects of topical hapten application. This effect is also not simply a completely nonspecific inflammatory stimulus, since doses of hapten that are sufficient to deliver this signal do not cause significant skin inflammation, whereas doses of irritants which already induce some skin inflammation by themselves do not potentiate CHS elicitation (Fig. 5 *b*). Although in a number of experiments we observed that application of irritant together with a low dose of specific hapten augmented the response to the applied hapten to some extent, we were unable to reconstitute a full-strength CHS response with this treatment (Fig. 5 *a*). Instead, the magnitude of this response was always greatly lower than that induced by the optimal challenge dose of the specific hapten. We conclude from these data that a mild irritative stimulus can provide a signal that synergizes with that of the specific hapten, but that this signal is not strong enough to evoke a potent CHS response when applied in conjunction with low-dose specific hapten. Using this experimental system, it is not possible to determine whether large doses of irritants enhance hapten-specific CHS, since they already produce maximal ear swelling responses on their own. In contrast, McLelland et al. (12) demonstrated that application of irritants to patch test sites in nickel-sensitive patients produced an enhanced CHS response. In our murine test system, however, low to intermediate con-

centrations of croton oil had only very modest effects on elicitation of CHS. Whether this discrepancy is due to differences between human and murine systems or between the type of haptens or irritants used in the respective studies remains to be determined. Moreover, McLelland and Shuster (13) found that combined application of subthreshold doses of two allergens, both of which the test person was sensitized to, resulted in an additive CHS response. In contrast, our experiments show that application of a conventional dose of hapten, to which the organism is not sensitized, leads to a greater than additive CHS response. This synergistic effect appears not to be due to an immunological response to the unrelated hapten, but due to nonimmunological, proinflammatory effects of topically applied haptens.

Detection of the nature of this proinflammatory stimulus might have important practical implications because a selective blockade of this stimulus might prevent elicitation of contact dermatitis despite contact with the specific allergen. Several groups have demonstrated that certain cytokines are induced selectively after hapten application but not after administration of irritants (14–17). Thus, in an attempt to further characterize the non-Ag-specific, inflammatory signal that appears to be required for elicitation of CHS, we injected various cytokines into ears of sensitized mice, which were subsequently painted with a low dose of specific hapten. The cytokines IL-1 $\alpha$ , IL-12, TNF $\alpha$ , GM-CSF, MIP-1 $\alpha$  had either no effect or produced a nonspecific inflammatory response by themselves. However, this does not rule out the possibility that these or other cytokines may still have a role in this response, since they might not have been administered at the appropriate time, at the right concentration, or in the correct combination. Likewise, we were not able to replace the irrelevant hapten by injecting IL-1 $\beta$ . Although in two of five experiments IL-1 $\beta$  synergized with low-dose hapten to elicit a statistically significant ear swelling response, this effect was not seen consistently. Moreover, a biologically obvious effect of IL-1 $\beta$ , comparable with that caused by coadministration of unrelated hapten, was only seen in one of five experiments. Thus, we are currently unable to conclude that IL-1 $\beta$  is of significant importance in our experimental system. Likewise, the current literature also reveals conflicting results as to whether induction of IL-1 $\beta$  is involved in elicitation of CHS. On the one hand, Enk et al. (14) were able to demonstrate that epicutaneous hapten application results in selective and almost immediate upregulation of IL-1 $\beta$ -mRNA in cutaneous LC, which is not observed after application of irritants or tolerogens. Moreover, these authors showed that *in vivo* administration of anti-IL-1 $\beta$  antibodies prior to epicutaneous hapten administration prevents sensitization (15). On the other hand, Zheng et al. (18) demonstrated recently that IL-1 $\beta$  gene knock-out mice exhibit normal CHS responses. Moreover, *in vivo* removal of epidermal LC (the cells that were identified as the major source of IL-1 $\beta$  after hapten painting) does not result in decreased CHS responses (2). Whether in these two models other cytokines can replace IL-1 $\beta$  remains to be determined.

Taken together, our data show that for elicitation of hapten-specific CHS responses, two signals appear to be required: (1) the specific Ag, and (2) a defined nonspecific proinflammatory signal. Both signals are induced by topical hapten application. Signal one requires only low amounts of hapten, whereas signal two requires relatively high amounts of hapten, thus determining the hapten concentration necessary for elicitation of

CHS. Therefore, it is not the antigenic component but rather the nonspecific proinflammatory capacity of haptens which determines the concentration dependence in allergic contact dermatitis.

## Acknowledgments

The authors wish to thank Drs. E. Macher, K. Steinbrink, and R.D. Granstein for helpful discussions and critical review of the manuscript.

This work was supported by grants from the German Research Association (Gr1022/3-1, Schw 625/2-1, and SFB 293/96-B1) and the European Community (BMH4-CT95-0872).

## References

1. Kripke, M.L., and W.L. Morison. 1986. Studies on the mechanism of systemic suppression of contact hypersensitivity by UVB radiation. II. Differences in the suppression of delayed and contact hypersensitivity in mice. *J. Invest. Dermatol.* 86:543-549.
2. Grabbe, S., K. Steinbrink, M. Steinert, T.A. Luger, and T. Schwarz. 1995. Removal of the majority of epidermal Langerhans cells by topical or systemic steroid application enhances the effector phase of murine contact hypersensitivity. *J. Immunol.* 155:4207-4217.
3. Gocinski, B.L., and R.E. Tigelaar. 1990. Roles of CD4+ and CD8+ T cells in murine contact sensitivity revealed by in vivo monoclonal antibody depletion. *J. Immunol.* 144:4121-4128.
4. Ullrich, S.E. 1995. The role of epidermal cytokines in the generation of cutaneous immune reactions and ultraviolet radiation-induced immune suppression. *Photochem. Photobiol.* 62:389-401.
5. Rycroft, R.J.G., T. Menné, and P.J. Frosch. 1995. *Textbook of Contact Dermatitis*. Springer, Berlin.
6. Schwarz, A., S. Grabbe, H. Riemann, Y. Aragane, M. Simon, S. Manon, S. Andrade, T.A. Luger, A. Zlotnik, and T. Schwarz. 1994. In vivo effects of interleukin-10 on contact hypersensitivity and delayed-type hypersensitivity reactions. *J. Invest. Dermatol.* 103:211-216.
7. Schwarz, A., S. Grabbe, Y. Aragane, K. Sandkuhl, H. Riemann, T.A. Luger, M. Kubin, G. Trinchieri, and T. Schwarz. 1996. IL-12 prevents ultraviolet-B induced local immunosuppression and overcomes ultraviolet-B induced tolerance. *J. Invest. Dermatol.* 106:1187-1191.
8. Cruz, P.D., Jr., J. Nixon-Fulton, R.E. Tigelaar, and P.R. Bergstresser. 1988. Local effects of UV radiation on immunization with contact sensitizers. I. Down-regulation of contact hypersensitivity by application of TNCB to UV-irradiated skin. *Photodermatol.* 5:126-132.
9. Willis, C.M., E. Young, D.R. Brandon, and J.D. Wilkinson. 1986. Immunopathological and ultrastructural findings in human allergic and irritant contact dermatitis. *Br. J. Dermatol.* 115:305-316.
10. Brasch, J., J. Burgard, and W. Sterry. 1992. Common pathogenetic pathways in allergic and irritant contact dermatitis. *J. Invest. Dermatol.* 98:166-170.
11. Montelius, J., H. Wahlkvist, A. Boman, P. Fermstrong, L. Grabergs, and J.E. Wahlberg. 1994. Experience with the murine local lymph node assay: inability to discriminate between allergens and irritants. *Acta Dermato-Venerol.* 74:22-27.
12. McLelland, J., S. Shuster, and J.N.S. Matthews. 1991. "Irritants" increase the response to an allergen in an allergic contact dermatitis. *Arch. Dermatol.* 127:1016-1019.
13. McLelland, J., and S. Shuster. 1990. Contact dermatitis with negative patch tests: the additive effect of allergens in combination. *Br. J. Dermatol.* 122:623-630.
14. Enk, A.H., and S.I. Katz. 1992. Early molecular events in the induction phase of contact sensitivity. *Proc. Natl. Acad. Sci. USA.* 89:1398-1402.
15. Enk, A.H., V.L. Angeloni, M.C. Udey, and S.I. Katz. 1993. An essential role for Langerhans cell-derived IL-1 beta in the initiation of primary immune responses in skin. *J. Immunol.* 150:3698-3704.
16. Kondo, S., S. Pastore, G.M. Shivji, R.C. McKenzie, and D.N. Sauder. 1994. Characterization of epidermal cytokine profiles in sensitization and elicitation phases of allergic contact dermatitis as well as irritant contact dermatitis in mouse skin. *Lymphokine Cytokine Res.* 13:367-375.
17. Haas, J., T. Lipkow, M. Mohamadzadeh, G. Kolde, and J. Knop. 1992. Induction of inflammatory cytokines in murine keratinocytes upon in vivo stimulation with contact sensitizers and tolerizing analogues. *Exp. Dermatol.* 1:76-83.
18. Zheng, H., D. Fletcher, W. Kozak, M. Jiang, K.J. Hofmann, C.A. Conn, D. Soszynski, C. Grabiec, M.E. Trumbauer, A. Shaw, et al. 1995. Resistance to fever induction and impaired acute-phase response in interleukin-1β-deficient mice. *Immunity* 3:9-19.