

## Enzymatically Inactive Red Cell Carbonic Anhydrase B in a Family with Renal Tubular Acidosis

Emmanuel Shapira, ... , Fabien G. Eyal, Alexander Russell

*J Clin Invest.* 1974;53(1):59-63. <https://doi.org/10.1172/JCI107559>.

**Research Article**

An inactive mutant form of red cell carbonic anhydrase B is described in three members of a large kindred who manifest infantile renal tubular acidosis and nerve deafness. A combination of enzymatic and immunologic investigations permitted its detection, despite the fact that both antigenic and electrophoretic properties of the mutant were identical to those of the normal form.

**Find the latest version:**

<https://jci.me/107559/pdf>



# Enzymatically Inactive Red Cell Carbonic Anhydrase B in a Family with Renal Tubular Acidosis

EMMANUEL SHAPIRA, YOAV BEN-YOSEPH, FABIEN G. EYAL, and  
ALEXANDER RUSSELL

*From the Department of Pediatrics and Child Care, Pediatric Research Unit,  
Hadassah University Hospital Medical School, Hebrew University, Jerusalem*

**ABSTRACT** An inactive mutant form of red cell carbonic anhydrase B is described in three members of a large kindred who manifest infantile renal tubular acidosis and nerve deafness. A combination of enzymatic and immunologic investigations permitted its detection, despite the fact that both antigenic and electrophoretic properties of the mutant were identical to those of the normal form.

## INTRODUCTION

Carbonic anhydrase (CA),<sup>1</sup> an enzyme which reversibly catalyzes the hydration of carbon dioxide, is particularly important in the regulation of acid-base status of the body, especially within the kidney. Genetic studies indicate the synthesis of two major isoenzymes, CA B and CA C, is controlled by a separate locus (1). The additional isoenzymes of CA described are "aging" products of one of the two major forms. These minor forms are immunologically identical to either the B or C major types, but no cross antigenicity exists between the two major forms (2, 3). CA B has less enzymatic activity and lower affinity for acetazolamide (Diamox) than CA C (4). These two major forms of the enzyme are distributed in varying proportions in the body, and since no tissue specificity appears to exist (5), erythrocytes should be useful for evaluation of these isoenzymes and mutants thereof.

Renal tubular acidosis (RTA) comprises a heterogeneous grouping of clinical syndromes classified as a

proximal form, with a basic defect in the tubular reabsorption of bicarbonate, and a distal form, reflecting an inability to sustain the pH gradient between blood and tubular fluid (6). It has been assumed that some cases of RTA might be due to decreased activity of CA. Indirect investigations by use of a CA inhibitor (acetazolamide) have failed to demonstrate such a defect (7). On the other hand, a recent description of a patient with proximal RTA ascribes the decreased acetazolamide inhibition to a possible deficiency or defect of the enzymatic activity of CA (8).

The present study was carried out in a family in which three members are affected with RTA and nerve deafness. The detailed genetic study of this family will be described elsewhere.<sup>2</sup>

## METHODS

*P*-Nitrophenyl acetate (PNPA) and acrylamide were obtained from British Drug Houses (Great Britain), hydroxylapatite (lot 7020) was obtained from Bio-Rad Laboratories (Richmond, Calif.), DEAE-cellulose from Sigma Chemical Co. (St. Louis, Mo.), and Sepharose 4B from Pharmacia Fine Chemicals, Inc. (Piscataway, N. J.), agar (Noble) from Difco Laboratories (Detroit, Mich.).

The preparation of hemolysates, hemoglobin-free hemolysates (HFH), purified CA B, as well as the quantitative determination of CA B, using a single radial immunodiffusion assay, with specific antiserum was performed as previously described (9).

The specific immunoabsorbant for CA B was prepared by binding 150 mg of the anti-CA B serum IgG fraction to 5 g of Sepharose 4B, according to Axen, Porath, and Ernback (10).

CA activity was determined by the following assays: (a) Esterase activity, using PNPA as substrate, was measured according to a slight modification of Armstrong,

Dr. Shapira's present address is The Children's Memorial Hospital, Chicago, Ill. 60614.

Received for publication 7 November 1972 and in revised form 22 August 1973.

<sup>1</sup>Abbreviations used in this paper: CA, carbonic anhydrase; HFH, hemoglobin-free hemolysates; PNPA, *p*-nitrophenyl acetate; RTA, renal tubular acidosis; TRP, tubular reabsorption of phosphate.

<sup>2</sup>Cohen, T., A. Brand-Aurban, C. Karshai, A. Jacob, I. Gay, J. Tsitsianov, T. Shapiro, S. Jatziv, and A. A. Ashkenazi. 1973. Familial infantile renal tubular acidosis and congenital nerve deafness: An autosomal recessive syndrome. Submitted for publication.

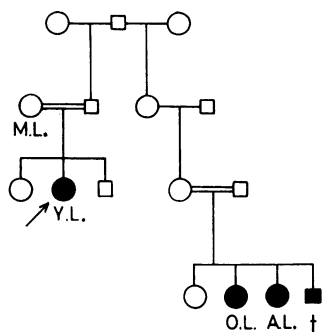

FIGURE 1 Pedigree of the family with RTA and nerve deafness.

Myers, Verporte, and Edsall (4). The reaction mixture contained 0.001 M PNPA in 0.01 M phosphate buffer at pH 7.4. Enzyme concentrations ranged from 1 to 10  $\mu$ M. The reference cuvette contained the same reaction mixture without enzyme. The increase in absorbance at 348 nm due to the net catalyzed reaction at room temperature was recorded by a Beckman DB spectrophotometer (Beckman Instruments, Inc., Fullerton, Calif.) with a quartz cell of 1 cm light path. The activity, expressed as  $\mu$ mole PNPA  $\cdot$  min<sup>-1</sup>, was calculated from the initial slopes.

(b) Hydration and dehydration activities of CA were measured according to Hansen and Magid (11), by an autotitrator (Radiometer Co., Copenhagen, model SBR C2) with a 0.25 ml autoburette (ABU 12), and combined electrode (GK 2302C). The reaction chamber was at a constant temperature and the enzymatic reaction was performed at pH 7.2 with the following modifications:

The hydration reaction was carried out at both 10 and 37°C. Carbon dioxide was continuously bubbled through 10 ml of 0.01 M phosphate buffer pH 7.2, until saturated (flow rate 500 ml/min). The spontaneous noncatalyzed hydration reaction was titrated with 1 N NaOH and recorded while the catalyzed reaction was measured, in the same manner, after addition of enzyme (0.1–1.0  $\mu$ M) to

the CO<sub>2</sub>-saturated buffer solution. Enzymatic activity was then calculated by subtraction.

The dehydration reaction was measured at 25°C in the same chamber. Nitrogen was bubbled continuously through the reaction mixture (10 ml of 0.075 M NaHCO<sub>3</sub> in 0.01 M phosphate buffer). After recording the spontaneous dehydration, (titrated with 1 N HCl), the enzymatically catalyzed reaction was measured and the enzyme activity calculated as described above.

Specific CA B activity was determined as follows: After ascertaining the total carbonic anhydrase activity of the hemolysate, the CA B was adsorbed using an insoluble specific immunoadsorbent. (Total adsorption of the CA B was demonstrated by absence of any material which cross-reacted immunologically with the specific anti-CA B serum.) The residual CA activity (i.e., CA C activity) was determined after the adsorption and the net CA B activity calculated by subtraction. The CA B concentration of the hemolysates was determined by immunoassay (9). The specific activity of CA B was calculated from the relative activity and concentration.

### CASE REPORT

The pedigree of the family with three members affected with RTA and nerve deafness is illustrated in Fig. 1. The propositus (Y. L.) manifested vomiting, failure to thrive, polyuria, and a tendency to dehydration in infancy. Nephrocalcinosis was identified in early childhood.

The following nephrological studies were performed at the age of 6 yr. Urine: no glycosuria, no aminoaciduria; urine output: 1,500–2,500 ml/24 h; urine osmolality: 263 mosmol/liter; blood osmolality: 312 mosmol/liter; creatinine clearance: 100 ml/min/1.73 m<sup>2</sup> body surface; tubular reabsorption of phosphate (TRP): 86%; and blood urea nitrogen: 14 mg/100 ml.

After induction of severe metabolic acidosis by ammonium chloride loading (75 meq/m<sup>2</sup>), blood acid-base status was: pH, 7.25; total CO<sub>2</sub>, 12 meq/liter; HCO<sub>3</sub><sup>-</sup>, 10.4 mM/liter; and base excess, -14.6. At this stage of metabolic acidosis urinary findings were: pH, 7.3; ammonia, 15.3 meq/min/1.73 m<sup>2</sup>; and titrable acid, 2.45 meq/min/1.73 m<sup>2</sup>. A continuous intravenous drip of sodium bicarbonate (2 M) was started at the rate of 60 ml/h. The correlation between urinary pH and serum bicarbonate is presented in Fig. 2. For all concentrations of serum bicarbonate there was a continuous high secretion of bicarbonate in the urine ranging from 9.0 to 17.5 mM/liter. Because of this continuous bicarbonate excretion, hydrogen ion clearance index was constantly negative, reaching -0.09 during severe acidosis (normal: +4.12–+1.36).

To control her acidosis the patient was treated with supplementary base as high as 20 meq/kg/day.

The primary base of RTA in this family was supported by (a) the absence of any associated systemic or metabolic disorder; (b) absence of evidence of

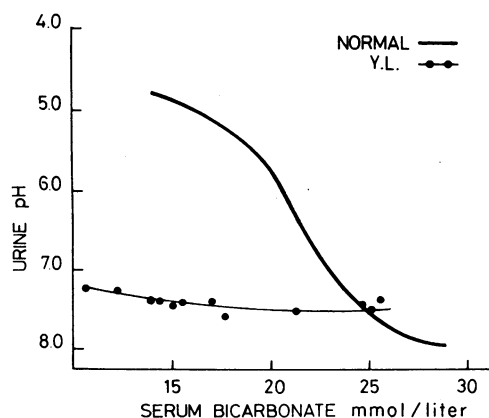

FIGURE 2 Relationship of urinary pH to serum bicarbonate concentrations in RTA patient (Y. L.), after administration of ammonium chloride and continuous intravenous bicarbonate infusion. The solid curve represents the mean response of normal children.

metal and/or drug intoxication, and (c) normal creatinine clearance and TRP.

## RESULTS

Identical patterns of CA isoenzymes were obtained after polyacrylamide gel electrophoresis of HFH (containing mainly CA) from both normal and the RTA patients (Fig. 3). Similarly, the antigenic properties of CA B in all the affected patients were identical to those of normal individuals when compared by double gel diffusion against specific anti-CA B serum: all hemolysates gave an identical precipitin line.

The relative concentration and activity of the two major CA isoenzymes was determined in hemolysates from three normal individuals: the three affected patients (Y. L., O. L., A. L.); and one obligatory heterozygote (M. L., mother of Y. L.), and were compared with purified CA B from normal individuals and one patient (Y. L.). The results of these experiments, employing a synthetic substrate PNPA, are summarized in Table I, whereas Table II depicts results using bicarbonate as substrate. The activity of CA C (hemolysates after CA B adsorption) in both the normal controls and in the patients was very similar. CA B activity in the normal controls was identical to that of purified normal CA B for both substrates, indicating the reliability of the procedure. In the family with RTA, CA B specific activity in the hemolysates was reduced to approximately one-third of normal using

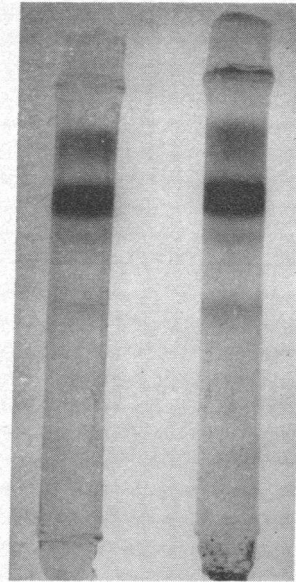

FIGURE 3 Identical patterns of CA isoenzymes in HFH after polyacrylamide gel electrophoresis (pH 8.5, 2 h). Gel on left from a patient (Y. L.) affected with RTA and gel on right from a normal individual.

PNPA as substrate (Table I). When using bicarbonate as a substrate (Table II) only 6% of the normal activity was observed. Using either substrate, CA B activity of the heterozygote (M. L.) was intermediate between the normal and affected individuals. Purified

TABLE I  
CA Activity after Hydrolysis of PNPA\*

Subjects	Esterase activity					
	Total hemolysate activity	After CA B adsorption	Net CA B activity	CA B immunoassay	CA B sp act	
		$\mu\text{mol} \cdot \text{min}^{-1} / \text{g Hb}$		$\text{mg} / \text{g Hb}$	$\mu\text{mol} \cdot \text{min}^{-1} / \text{mg}$	
Normal	41 N	10.2	4.3	5.9	14.2	0.415
Controls	42 N	10.4	4.2	6.2	14.8	0.420
	43 N	11.0	4.3	6.7	14.7	0.455
Purified Normal CA B						0.427
Family members affected with RTA						
	A. L.	7.2	4.3	2.9	17.5	0.166
	O. L.	7.4	4.8	2.6	17.9	0.145
	Y. L.	8.2	4.8	3.4	22.5	0.150
Y. L. mother	M. L.	9.2	4.2	5.0	16.4	0.305
Purified CA B from patient	Y. L.					0.173

\* PNPA,  $10^{-3}$  N; pH 7.4.

TABLE II  
CA Activity after Dehydration of HCO<sub>3</sub>\*

Subjects	Dehydrase activity					
	Total hemolysate activity	After CA B adsorption	Net CA B activity	CA B immunoassay	CA B sp act	
	$\mu\text{mol} \cdot \text{min}^{-1}/\text{g Hb}$			$\text{mg/g Hb}$	$\mu\text{mol} \cdot \text{min}^{-1}/\text{mg}$	
Normal	41 N	7.4	2.8	4.6	14.2	0.324
	42 N	7.6	3.2	4.4	14.8	0.297
	43 N	6.8	2.2	4.6	14.7	0.313
Purified Normal CA B						0.320
Family members affected with RTA	A. L.	2.4	2.0	0.4	17.5	0.023
	O. L.	3.2	2.8	0.4	17.9	0.022
	Y. L.	3.2	2.8	0.4	22.5	0.018
Y. L. mother	M. L.	4.8	2.3	2.5	16.4	0.146
Purified CA B from patient	Y. L.					0.020

\* HCO<sub>3</sub>, 0.075 M pH 7.2.

CA B, isolated from the patient, had the same specific activity as that in hemolysates of the three affected siblings. Although quantitatively different in their specific activity, the two purified CA B preparations (normal and mutant) demonstrated an identical precipitin line in double gel diffusion, indicating antigenic identity.

Fig. 4 illustrates the hydrase activity using CO<sub>2</sub> as substrate, for the normal and mutant purified CA B

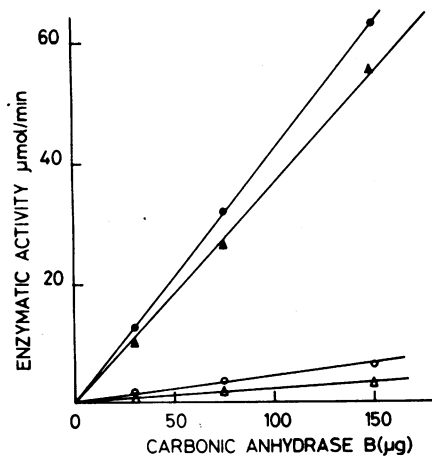

FIGURE 4 CO<sub>2</sub> hydration activity by purified CA B preparations at two substrate concentration (○), 0.053 M; (△), 0.025 M. (○, △), purified mutant form of CA B and (●, ▲), normal form.

preparations. At these high substrate concentrations (0.053 M at 10°C and 0.025 M at 37°C) the mutant CA B demonstrated only 7–11% of normal activity.

Although the purified mutant CA B variant was immunologically and electrophoretically identical to the normal CA B, distinct physicochemical differences could be demonstrated. The specific extinction coefficient ( $E_{1\%}^{1\text{cm}}$ ) at 280 nm was found to be 16.3 for the normal and 14.5 for the mutant while at 294 nm it was 14.6 and 13.7, respectively.

The normal and mutant CA B preparations were dialyzed overnight against 8 M urea (pH 7.0 at 4°C). After removal of the urea, (dialysis against phosphate-buffered saline for 72 h with four buffer changes) the mutant preparation lost all its enzymatic activity and did not cross-react with the anti-CA B antibodies. This was in contrast to the normal CA B which retained completely both enzymatic and antigenic activity. In addition, the normal and mutant CA B preparations were incubated for 1 h at 55°C (in phosphate-buffered saline pH 7.0). The mutant enzyme was found to lose completely its enzymatic activity and antigenic cross-reactivity whereas the normal enzyme retained 85% of both.

## DISCUSSION

Evidence for a mutant form of CA B with decreased activity for PNPA hydrolysis (Table I) and an extremely low activity for reversible hydration of CO<sub>2</sub>

(Table II and Fig. 4) was observed in the three affected members of the family studied. The different specific activity of the enzyme on various substrates, and preliminary kinetic studies using the purified mutant of CA B, indicate that enzyme-substrate complex formation is affected.

Since the mutant form manifested electrophoretic and antigenic identities with the normal isoenzyme, only a combination of both enzymatic and immunologic determinations allowed its detection.

The mutant enzyme from the affected patients had an extremely low specific activity for both physiological substrates used (bicarbonate and CO<sub>2</sub>) even when such activity was measured at substrate concentrations far greater than physiological. Based on control values, a decrease in substrate concentration yielded a far greater than expected relative decrease of mutant enzyme activity (Fig. 4). Therefore, it is highly likely that the mutant CA B will have practically no activity at physiological concentrations. It is also noteworthy that an asymptomatic heterozygote (M. L.) had approximately half of the expected level of the normal CA B activity.

Calculation of the tyrosine and tryptophan residues from the specific extinction coefficients at 280 and 294 nm (12) revealed the presence of eight tyrosine and six tryptophan residues per molecule for the normal CA B preparations. These values are identical with those found by amino acid analysis (13). The mutant CA B form had the same six tryptophans but only seven tyrosine residues.

The decreased urea and temperature stability of the mutant form as compared with the normal variant suggests a higher conformational instability of this mutant protein.

Physiological studies indicate that luminal CA activity in the nephron should be confined to the proximal tubule (14). Histochemical studies confirmed this proximal luminal CA activity and furthermore demonstrated intracellular CA activity in both the proximal and distal tubule (15). Since the two major isoproteins CA are distributed in varying proportions in different body tissues, and no tissue specific isoenzyme form is known to exist (5), the inactive form of CA B found in the red cell of our patients suggests that CA B may have a major role in renal tubular acidification.

We have also examined two other cases of RTA, one in association with Fanconi's syndrome and the second with cystinosis. In both of these patients the two major CA isoenzymes were normal. Thus our studies suggest a conceptually new pathogenic basis for the form of RTA observed in our family. The association of RTA with nerve deafness may comprise a new clinicopathological entity, the specificity and inci-

dence of which will emerge only after detailed studies of CA isoenzymes on other cases of persistent RTA.

#### ACKNOWLEDGMENTS

We are indebted to Miss Miriam Cohen and to Mrs. Miriam Meshulam for their skilled technical assistance. This work was supported by a grant from the Reuben Kunin-Samuel Lunenfeld Medical Research Foundation.

#### REFERENCES

1. Tashian, R. E. 1965. Genetic variation and evolution of the carboxylic esterases and carbonic anhydrases of primate erythrocytes. *Am. J. Hum. Genet.* **17**: 257.
2. Funakoshi, S., and H. F. Deutsch. 1970. Human carbonic anhydrases. III. Immunochemical studies. *J. Biol. Chem.* **245**: 2852.
3. Funakoshi, S., and H. F. Deutsch. 1971. Human carbonic anhydrases. VI. Levels of isoenzymes in old and young erythrocytes and in various tissues. *J. Biol. Chem.* **246**: 1088.
4. Armstrong, J. McD., D. V. Myers, J. A. Verpoorte, and J. T. Edsall. 1966. Purification and properties of human erythrocyte carbonic anhydrases. *J. Biol. Chem.* **241**: 5137.
5. Wistrand, P. J., and S. N. Rao. 1968. Immunologic and kinetic properties of carbonic anhydrases from various tissues. *Biochim. Biophys. Acta.* **154**: 130.
6. Morris, R. C. 1969. Renal tubular acidosis. Mechanism, classification and implications. *N. Engl. J. Med.* **281**: 1405.
7. Soriano, J. R., H. Boichis, H. Stark, and C. M. Edelmann, Jr. 1967. Proximal renal tubular acidosis. A defect in bicarbonate reabsorption with normal urine acidification. *Pediatr. Res.* **1**: 81.
8. Donckerwolcke, R. A., G. J. Van Stekelenburg, and H. A. Tiddens. 1970. A case of bicarbonate-losing renal tubular acidosis with defective carbonic anhydrase activity. *Arch. Dis. Child.* **45**: 769.
9. Ben-Yoseph, Y., E. Shapira, and A. Russell. 1971. Quantitative determination of human carbonic anhydrase B isozyme. *Isr. J. Med. Sci.* **9**: 1050.
10. Axen, R., J. Porath, and S. Ernback. 1967. Chemical coupling of peptides and proteins to polysaccharides by means of cyanogen halides. *Nature (Lond.)* **214**: 1302.
11. Hansen, P., and E. Magid. 1966. Studies on a method of measuring carbonic anhydrase activity. *Scand. J. Clin. Lab. Invest.* **18**: 21.
12. Goodwin, T. W., and R. A. Morton. 1946. The spectrophotometric determination of tyrosine and tryptophan in proteins. *Biochem. J.* **40**: 628.
13. Armstrong, J. McD., D. V. Myers, J. A. Verpoote, and J. T. Edsall. 1966. Purification and properties of human erythrocyte carbonic anhydrases. *J. Biol. Chem.* **241**: 5137.
14. Rector, F. C., Jr., N. W. Carter, and D. W. Seldin. 1965. The mechanism of bicarbonate reabsorption in the proximal and distal tubules of the kidney. *J. Clin. Invest.* **44**: 278.
15. Hausser, C. 1958. Zur technik und spezifität des histochemischen carbonhydrasenachweises im modelivertuch und in gewebsschnitten von rattennieren. *Zellforsch. Mikrosk. Anat. Abt. Histochem.* **1**: 29.