

Electrophoretic and functional variants of NADH-methemoglobin reductase in hereditary methemoglobinemia

Hsin-Soon Hsieh, Ernst R. Jaffé

J Clin Invest. 1971;**50**(1):196-202. <https://doi.org/10.1172/JCI106473>.

Research Article

The electrophoretic mobility and activity of NADH-methemoglobin reductase in erythrocytes of patients with hereditary methemoglobinemia, obligatory heterozygotes, and normal subjects were examined. Six distinct electrophoretic variants were found in studies of erythrocytes from members of ten different families. Five variants (Boston Slow, Duarte, Princeton, Puerto Rico, and California) were associated with significant methemoglobinemia and moderate to marked decreases in enzymic activity. Precise correlations between levels of NADH-methemoglobin reductase activity, electrophoretic mobility, and clinical severity of methemoglobinemia, however, could not be drawn. One variant (Boston Fast) was associated with almost normal activity and very minimal methemoglobinemia. Nine members from three generations of two Italian families were found to have two bands with NADH-methemoglobin reductase activity in their erythrocytes, one with normal mobility and one with a mobility identical with that of Boston Fast. No functional or clinical impairment could be attributed to this abnormality. The observations made in this investigation were consistent with an autosomal recessive mode of inheritance of multiple alleles for NADH-methemoglobin reductase. As has been shown to be true for hemoglobin and glucose-6-phosphate dehydrogenase, multiple aberrations in the NADH-methemoglobin reductase of human erythrocytes apparently exist, some with and some without functional consequences.

Two bands with NADPH-methemoglobin reductase activity with electrophoretic mobilities distinct from those of the NADH-methemoglobin reductase were found in human erythrocytes. These bands were normal in [...]

Find the latest version:

<https://jci.me/106473/pdf>



Electrophoretic and Functional Variants of NADH-Methemoglobin Reductase in Hereditary Methemoglobinemia

HSIN-SOON HSIEH and ERNST R. JAFFÉ

*From the Department of Medicine, Albert Einstein College of Medicine—
Bronx Municipal Hospital Center, Bronx, New York 10461*

ABSTRACT The electrophoretic mobility and activity of NADH-methemoglobin reductase in erythrocytes of patients with hereditary methemoglobinemia, obligatory heterozygotes, and normal subjects were examined. Six distinct electrophoretic variants were found in studies of erythrocytes from members of ten different families. Five variants (Boston Slow, Duarte, Princeton, Puerto Rico, and California) were associated with significant methemoglobinemia and moderate to marked decreases in enzymic activity. Precise correlations between levels of NADH-methemoglobin reductase activity, electrophoretic mobility, and clinical severity of methemoglobinemia, however, could not be drawn. One variant (Boston Fast) was associated with almost normal activity and very minimal methemoglobinemia. Nine members from three generations of two Italian families were found to have two bands with NADH-methemoglobin reductase activity in their erythrocytes, one with normal mobility and one with a mobility identical with that of Boston Fast. No functional or clinical impairment could be attributed to this abnormality. The observations made in this investigation were consistent with an autosomal recessive mode of inheritance of multiple alleles for NADH-methemoglobin reductase. As has been shown to be true for hemoglobin and glucose-6-phosphate dehydrogenase, multiple aberrations in the NADH-methemoglobin reductase of human erythrocytes apparently exist, some with and some without functional consequences.

Two bands with NADPH-methemoglobin reductase activity with electrophoretic mobilities distinct from those of the NADH-methemoglobin reductase were

This work was presented in part at the 12th Annual Meeting of the American Society of Hematology, Cleveland, Ohio, 9 December 1969, and has been published in abstract form (1).

Dr. Jaffé is a Career Scientist of the Health Research Council of the City of New York (I-169).

Received for publication 4 June 1970 and in revised form 27 August 1970.

found in human erythrocytes. These bands were normal in hemolysates of erythrocytes from patients with hereditary methemoglobinemia, but were absent from the hemolysate of erythrocytes deficient in NADPH-methemoglobin reductase activity. These latter erythrocytes, however, contained normal concentrations of methemoglobin and had a normal ability to reduce methemoglobin *in vitro*. These observations were most consistent with the thesis that the NADH-methemoglobin reductase, distinct from any NADPH-methemoglobin reductase, was the major system responsible for the reduction of methemoglobin to hemoglobin in human erythrocytes.

INTRODUCTION

Hereditary methemoglobinemia due to a decreased ability of the erythrocytes to reduce methemoglobin has most often been associated with deficient activity of the NADH-methemoglobin reductase system (2). Direct evidence that NADH-methemoglobin reductase activity was impaired in the erythrocytes of patients with hereditary methemoglobinemia was first provided by Scott and Griffith in 1959 (3). An abnormal enzymic component could not be demonstrated even after partial purification of the enzyme from hemolysates of the erythrocytes of Alaskan Eskimos and Indians with this disorder (4, 5). Recent reports from several laboratories, however, have described electrophoretic variants of this enzyme system (6-10). The investigation reported here has defined six different electrophoretic variants of NADH-methemoglobin reductase which were observed in studies of erythrocytes from members of ten different families. One of these variants appeared to be associated with only a minimal decrease in activity.

METHODS

Blood specimens were collected in potassium EDTA or acid citrate dextrose solution (ACD, NIH formula A) from seven patients with hereditary methemoglobinemia, 16 heterozygous subjects, and 56 normal controls. Storage of these

specimens at 4°C for at least 1 wk did not affect the results obtained. Methemoglobin concentrations were determined by the method described by Evelyn and Malloy (11). Starch gel electrophoresis at pH 8.6 revealed only normal hemoglobin components in the erythrocytes of the patients, and the absorption spectra of the methemoglobin and cyanmethemoglobin derivatives were normal. NADH-methemoglobin reductase activity was assayed by two different procedures, a modification of the diaphorase method of Scott and Griffith described previously (12) and the methemoglobin-ferrocyanide method as reported by Hegesh, Calmanovici, and Avron (13).

For electrophoresis, erythrocytes were obtained by thrice washing the cells in isotonic sodium chloride solution with centrifugation at room temperature. Washed cells, suspended in an equal volume of isotonic sodium chloride solution, were hemolyzed by freezing in a dry ice-alcohol bath and thawing in warm water three times. Clear hemolysates were obtained after centrifugation at 1000 *g* for 30 min. To obtain 30-50-fold purified enzyme extracts, hemolysates were added to DEAE-Cellulose 52, Whatman designation for preswollen, microgranular diethylaminoethyl (DEAE) cellulose anion exchanger (H. Reeve Angel & Co. Ltd, London, England), which had previously been equilibrated with 0.005 M Tris-phosphate buffer, pH 6.8 (about 20 g DE52 per 5 ml of packed cells). Hemoglobin was removed by washing this mixture with the same buffer solution on a Buchner funnel until the filtrate became colorless. The enzyme extract was recovered in the eluate obtained after mixing the slurry with 0.5 M KCl, pH 5.6. This procedure was a minor modification of the method described by Hennessey, Waltersdorph, Huennekens, and Gabrio (14). The eluate was concentrated by dialysis against 0.1 M Tris buffer, pH 7.4, under reduced pressure for 6-12 hr. Whole hemolysates or partially purified enzyme extracts which had been adjusted to contain enzyme activity capable of reducing from 3 to 5 nmoles of methemoglobin per minute were applied to the slots of a starch gel for electrophoresis. Vertical electrophoresis at pH 9.3 and 4°C and staining for NADH- or NADPH-methemoglobin reductase were performed as described by Kaplan and Beutler (8). This staining procedure depended upon the indophenol-mediated reduction of the tetrazolium dye by the reduced pyridine nucleotides. Although this reaction did not involve the reduction of methemoglobin itself, deficiency in the ability to reduce methemoglobin has been correlated with deficiency in the capacity to reduce an indophenol dye (5, 12, 13) and with decreased or absent staining of the "diaphorase" bands after electrophoresis (6, 8, 9). Convention, therefore, has resulted in the designation of these bands as methemoglobin reductases. The distance of migration was measured from the center of the band or bands staining for NADH-methemoglobin reductase activity. Relative mobility of bands with an abnormal migration was calculated by dividing the distance of migration of the abnormal band by the distance of migration of the normal band on the same starch gel and multiplying by 100.

The ability of intact erythrocytes to reduce nitrite-induced methemoglobin *in vitro* was evaluated by the procedure described in detail previously (12).

RESULTS

A single band with NADH-methemoglobin reductase activity, moving toward the anode but not as far as hemoglobin, was demonstrated with the hemolysates of

erythrocytes from 56 normal subjects. Electrophoresis of partially purified enzyme extracts prepared from these hemolysates revealed a band that migrated the same distance. Electrophoresis of hemolysates deficient in NADH-methemoglobin reductase activity revealed either a faint or no visible band. A single band with a mobility different from that of the normal was demonstrated for each of seven patients with hereditary methemoglobinemia upon electrophoresis of partially purified enzyme extracts. The mobility of these abnormal bands relative to that of the normal band was consistent on repeated determinations with whole hemolysates, when an abnormal band could be detected, and with partially purified enzyme extracts.

Only one band was observed when normal hemolysates containing about 2 g/100 ml of hemoglobin or the equivalent amounts of a partially purified enzyme extract were subjected to electrophoresis. An additional, more anodic band with NADH-methemoglobin reductase activity was seen after electrophoresis of more concentrated preparations. The intensity of staining of this band was inconstant and tended to vary on different occasions with preparations obtained from the same subject. Correspondingly, more rapidly migrating minor bands with mobilities different from each other and from the faster band of normal controls could be demonstrated after electrophoresis of sufficiently large amounts of partially purified enzyme extracts from both methemoglobinemic and heterozygous subjects with the six electrophoretic variants described below.

The characteristics of the six different variants of NADH-methemoglobin reductase are summarized in Table I where they are listed in the order of their relative electrophoretic mobility.

The Boston Slow variant was characterized by Bloom and Zarkowsky (9) in studies performed with blood from their patient No. 7, originally reported by Keitt, Smith, and Jandl (15). Although methemoglobin levels as high as 27% had been noted previously, the concentration at the time of the present study was only 9.5%. NADH-methemoglobin reductase activity was about 40% of normal. The relative electrophoretic migration of the single band observed with both a fresh hemolysate and a partially purified enzyme extract was 90% of normal. Blood relatives of this woman of Irish parentage were not available for examination.

The Duarte variant appeared as a rather broad band with a relative electrophoretic mobility of 108% that could be demonstrated only after electrophoresis of a partially purified enzyme extract. The patient, a man of English and Polish parentage, had an erythrocytosis (packed erythrocyte volume 53%) and possible angina. A methemoglobin concentration of 40% had been reported, but therapy with ascorbic acid had reduced the

TABLE I
Characteristics of Electrophoretic Variants of NADH-Methemoglobin Reductase

Preliminary designation	Ethnic origin	Relative electrophoretic mobility	Whole blood methemoglobin	NADH-methemoglobin reductase activity
		%	%	$\mu\text{moles/min per g hgb}$
Normal (56)		100	0.6 \pm 0.3	2.86 \pm 0.60
Boston Slow	Irish	90	9.5	1.08
Duarte	English/Polish	108	6.8 \ddagger	0.34
Princeton	Anglo-Saxon	113*	0.9*, 0.9*	0.94*, 1.25*
Puerto Rico	Puerto Rican	117	11.1, 20.0, 21.0	0.18, 0.67, 0.33
Boston Fast	Italian	127	3.4	2.17
California	Unknown	133	14.4	25% of normal \S

* Observed in asymptomatic heterozygotes; homozygote not available.

\ddagger While receiving ascorbic acid.

\S Reported by Kaplan and Beutler (8).

level to between 7 and 13%.¹ NADH-methemoglobin reductase activity was about 12% of normal.

Blood samples were obtained from the parents of three children with hereditary methemoglobinemia (methemoglobin levels of 10–30%) and severe mental retardation (16). Electrophoresis of partially purified enzyme extracts revealed one band of NADH-methemoglobin reductase activity with normal mobility and a second less intensely staining band with a relative mobility of 113%. Although the concentrations of methemoglobin in the blood of the asymptomatic parents were less than 1%, the NADH-methemoglobin reductase activities were only 33–44% of normal. The parents were of Anglo-Saxon extraction. Unfortunately, none of the severely affected children with the Princeton variant was available for study.

Three apparently unrelated Puerto Rican women with methemoglobinemia (11–31%) and erythrocyte NADH-methemoglobin reductase activities between 6 and 23% of normal were found to have an identical electrophoretic variant (Puerto Rico) with a relative mobility of 117% of normal. This variant was seen as a very faint band after electrophoresis of whole hemolysates and as a distinct single band after electrophoresis of a partially purified enzyme extract. Five children of one of these patients (16) were also examined. The NADH-methemoglobin reductase activities in the hemolysates of their erythrocytes ranged between 0.94 and 1.61 $\mu\text{moles/min per gram of hemoglobin}$ (average 1.28 or about 45% of normal). Partially purified enzyme extracts prepared from their erythrocytes were all found to have two bands with NADH-methemoglobin reductase activity after electrophoresis, one with normal mobility and a less darkly staining one with a mobility identical with that

of the single band demonstrated with the extract of their methemoglobinemic mother's erythrocytes.

The Boston Fast (Italian) variant was discovered by pure chance upon examination of a hemolysate of the erythrocytes of a woman with severe rheumatic heart disease and a Coomb's positive hemolytic process. One band with NADH-methemoglobin reductase activity had a normal electrophoretic migration, while a second band staining with approximately equal intensity had a relative mobility of 127%. This double band pattern was observed after electrophoresis of both whole hemolysates and partially purified enzyme extracts (Fig. 1). A family study revealed the same pattern in the hemolysates of the erythrocytes of four members in three generations of this Italian family (Fig. 2, family B), as well as in five members in three generations of another presumably unrelated Italian family (Fig. 2, family D). The erythrocytes of these subjects had both normal NADH-methemoglobin reductase activities and normal capacities to reduce nitrite-induced methemoglobin *in vitro*. The more rapidly migrating NADH-methemoglobin reductase band had an electrophoretic mobility identical with that of the single band observed by Bloom and Zarkowsky (9) with the hemolysate of the erythrocytes of their patient No. 8 (Fig. 1). The concentration of methemoglobin in the blood of this woman of Italian extraction was only 3%, and the NADH-methemoglobin reductase activity by both the diaphorase and the methemoglobin-ferrocyanide methods was 62–75% of normal. The ability of her erythrocytes to reduce nitrite-induced methemoglobin *in vitro* was only slightly impaired (about 90% of the normal control). In contrast, only limited reduction of methemoglobin was observed with the erythrocytes of patients with higher initial levels of methemoglobin and lower levels of NADH-methemoglobin reductase activity.

¹ Beutler, E. Personal communication.

Erythrocytes, frozen with glycerol, from the patient originally described by Kaplan and Beutler (8) with the California variant were available for study. A single band with a relative mobility of 133% of normal was observed after electrophoresis of a partially purified enzyme extract. These authors had reported a NADH-diaphorase activity of about 25% of normal in her cells. Her ethnic origin was unknown because she was an orphan; she was described as a white American.¹

In confirmation of the results reported by others (5, 13), both the diaphorase and the methemoglobin-ferrocyanide method permitted a clear distinction between normal subjects and patients with significant methemoglobinemia. Intermediate levels of activity were noted with hemolysates of the erythrocytes from obligatory heterozygotes and from cord blood of newborn infants. Hemolysates with the double band pattern, normal plus Boston Fast (Italian) variant, had normal activities with both methods. The correlation between the two methods was excellent with hemolysates with normal or intermediate levels of activity. The correlation when NADH-methemoglobin reductase activity was extremely

low was not as good because of the negative values obtained with deficient hemolysates with the modification of the original diaphorase method (12). The methemoglobin-ferrocyanide method had the advantages of being specific for NADH, having a faster rate, and involving a simpler procedure. The data obtained with this method, therefore, have been presented in Table I.

When the NADH in the staining mixture was replaced by an equimolar amount of NADPH, two bands were observed after electrophoresis (Fig. 3). One ill-defined band migrated to a more anodal position than hemoglobin. The second, sharper, band migrated with hemoglobin A and, therefore, was obscured on electrophoresis of whole hemolysates. These bands were normal in the hemolysates of all subjects with electrophoretically abnormal NADH-methemoglobin reductases. The NADH-methemoglobin reductase band was stained in the presence of NADPH after electrophoresis of partially purified enzyme extracts, but the NADPH-methemoglobin reductase did not show appreciable cross-reactivity with NADH. Both bands with NADPH-methemoglobin reductase activity were absent after electrophoresis of hemolysate and partially purified enzyme extract of the erythrocytes of the patient reported by Sass, Caruso, and Farhangi (17) to be deficient in NADPH-methemoglobin reductase activity (Fig. 3). The normal band with NADH-methemoglobin reductase activity was present. This patient's erythrocytes contained a normal concentration of methemoglobin, their ability to reduce nitrite-induced methemoglobin was normal (17), and the NADH-methemoglobin reductase activity was 4.32 μ moles/min per gram of hemoglobin.

DISCUSSION

The data presented here have provided evidence for the genetic and biochemical polymorphism of the disorder, hereditary methemoglobinemia, associated with a deficiency in the activity of NADH-methemoglobin reductase. The six electrophoretic variants of this enzyme system were associated with extremely slight (Boston Fast) to marked, but variable, decreases in enzymic activity. Similarly, minimal to marked degrees of methemoglobinemia were noted in erythrocytes containing an electrophoretically homogeneous, but abnormal, band with NADH-methemoglobin reductase activity. Significant methemoglobinemia was usually associated with a marked decrease in the activity of NADH-methemoglobin reductase. Precise correlations between levels of activity, electrophoretic mobility, and clinical severity of the methemoglobinemia, however, could not be drawn. The patients with the Duarte, Puerto Rico, and California variants all had significant methemoglobinemia and the NADH-methemoglobin reductase activities in hemolysates of their erythrocytes were 25% of normal

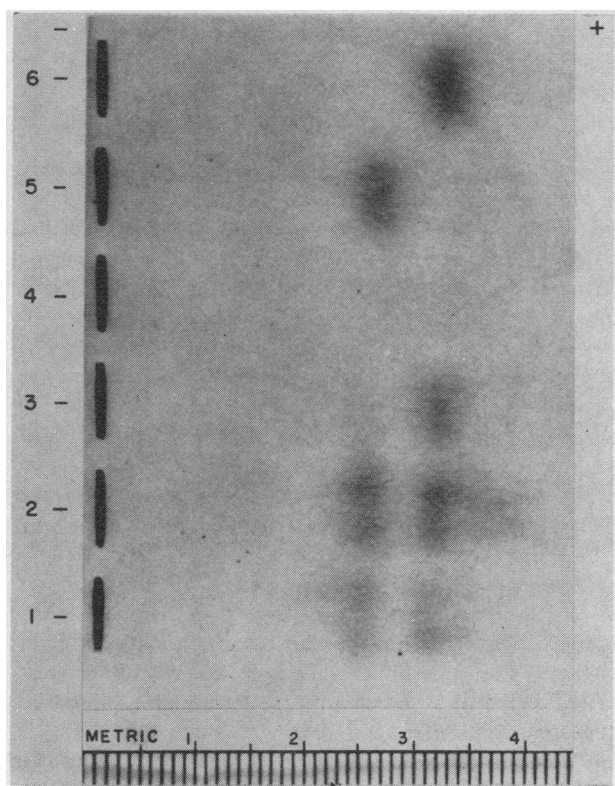

FIGURE 1 NADH-methemoglobin reductase. Starch gel electrophoresis, pH 9.3, of partially purified enzyme extracts. Slot 1, propositus of family B; slot 2, propositus of family D; slots 3 and 6, patient with single Boston Fast band; slot 4, diluted extract of erythrocytes from propositus of family D; slot 5, normal control.

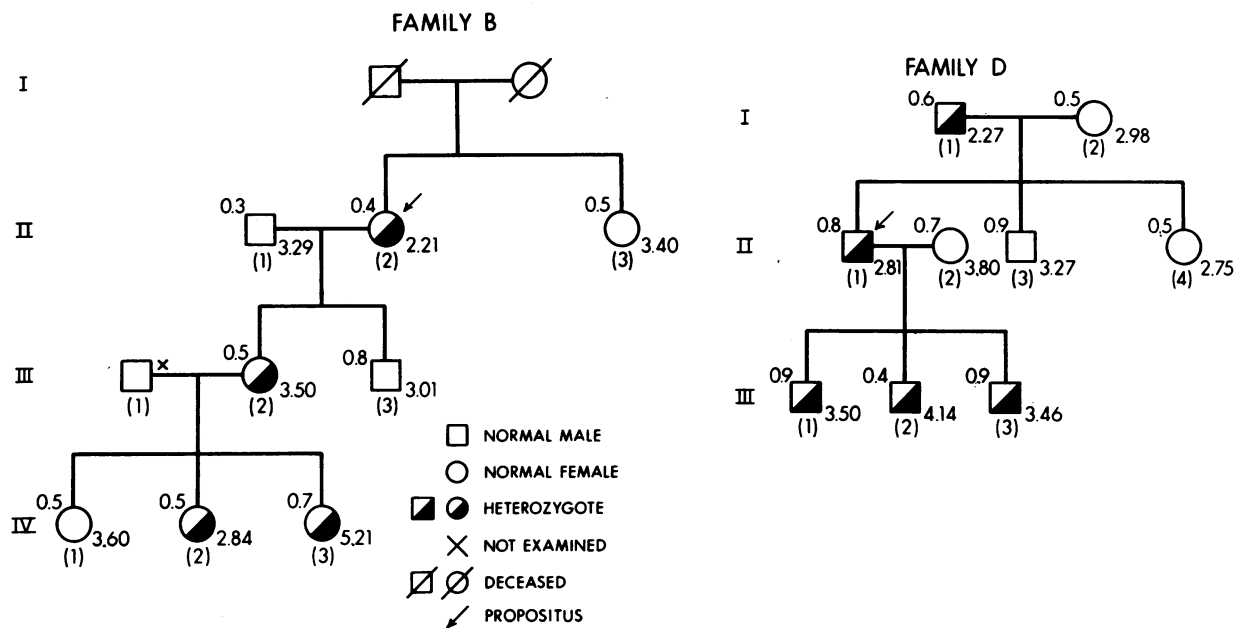

FIGURE 2 Pedigrees of two Italian families with normal and Boston Fast variant of NADH-methemoglobin reductase. Half-shaded symbols indicate presence of double band pattern after electrophoresis of hemolysate and partially purified enzyme extract. Figure above and to left of symbol indicates concentration of methemoglobin in per cent of total hemoglobin, and figure below and to right of symbol indicates NADH-methemoglobin reductase activity in μ moles per minute per gram of hemoglobin.

or lower. The degree of methemoglobinemia in the patient with the Boston Slow variant was similar, but the level of NADH-methemoglobin reductase activity (about 40% of normal) was comparable to that in the erythrocytes of the subjects heterozygous for the Princeton and Puerto Rico variants. These latter subjects were not methemoglobinemic, although their erythrocytes had been shown to have a decreased ability to reduce methemoglobin in vitro (16). The erythrocytes of the patient with the single band of NADH-methemoglobin reductase activity designated Boston Fast contained 3% methemoglobin. The level of activity of NADH-methemoglobin reductase was 62-75% of normal, and the capacity of her erythrocytes to reduce methemoglobin in vitro was only slightly impaired. Factors other than the NADH-methemoglobin reductase with an altered electrophoretic mobility may have been responsible for the low, but abnormal, level of methemoglobin in this individual's erythrocytes. Unfortunately, studies of this patient and her family have not been completed, and no conclusion about the mechanism for the slight elevation in methemoglobin content would be valid. Since levels of enzymic activity assayed under optimal conditions in hemolysates may not reflect the capability of the complete system in an intact erythrocyte, the lack of exact correlation between activity and methemoglobin content may not be too surprising.

The electrophoretic band designated Boston Fast may be relatively common. Since the activity of this variant did not appear to be markedly decreased, subjects whose erythrocytes contained this altered enzyme would not be expected to have clinically significant methemoglobinemia. Two families with a double band pattern were observed in the present investigation. Recently, Detter, Anderson, and Giblett (10) reported two patients whose erythrocytes showed a double band pattern on starch gel electrophoresis at pH 7.0. We have exchanged blood samples with this group of investigators. In both laboratories, the hemolysates of erythrocytes from their patient, Mrs. G. (Scotch-Irish and English origin), and from the propositus of our family D (Italian origin) revealed identical double band patterns after electrophoresis. In addition, Detter has observed another individual, Miss E. (Syrian origin), whose hemolysate also demonstrated the same double band pattern in both laboratories. This latter patient's enzyme, however, appeared to be more unstable upon heating than that of Mrs. G. and of normal erythrocytes.² Decreased affinity for NADH, increased affinity for 2,6-dichlorobenzene indophenol, retarded utilization of deamino-NADH, and moderately reduced thermal stability have been reported recently for the Puerto Rico variant (18). For

² Detter, J. C. Personal communication.

some patients with hereditary methemoglobinemia, no visible bands with NADH-methemoglobin reductase activity have been detected, even after electrophoresis of partially purified enzyme extracts (8, 9). There may exist, therefore, multiple structural aberrations in the NADH-methemoglobin reductase of human erythrocytes, some with differences in charge and some with alterations in functional or stability characteristics. Determination of the physicochemical properties and the amino acid composition of the various electrophoretic variants after isolation and purification of the enzyme system will be required to permit a molecular definition of the different variants.

Two other variants of NADH-methemoglobin reductase with altered electrophoretic mobilities have been reported (6, 7). Because they have not been examined under comparable experimental conditions, their relationships to the variants described here could not be established.

The nature of the inconstant, minor, more anodic band with NADH-methemoglobin reductase activity noted after electrophoresis of concentrated hemolysates and partially purified enzyme extracts in the present and previous studies (7, 9, 10) has not been defined. This minor band may represent a degradation product or subunits of the major component with NADH-methemoglobin reductase activity. The electrophoretic mobility of this minor band in normal hemolysates differed from that observed with the six different abnormal electrophoretic variants. The minor band, therefore, probably did not correspond to the NADH-dehydrogenase II suggested by Scott (4) to account for the residual methemoglobin reductase activity in the erythrocytes of Eskimos with hereditary methemoglobinemia.

All of the observations reported here are consistent with the thesis that NADH-methemoglobin reductase is under the control of an autosomal structural gene. The double band pattern observed to have been inherited in two families in the present investigation and in the studies of Detter et al. (10) and the finding of a normal and an abnormal band in hemolysates of erythrocytes of obligatory heterozygotes for hereditary methemoglobinemia (6, 8) support the concept of multiple alleles for NADH-methemoglobin reductase.

The reduction of methemoglobin to hemoglobin in normal human erythrocytes has been shown to depend primarily on a system requiring the generation of reduced pyridine nucleotides (2). Scott and McGraw (19) isolated and purified a NADH-methemoglobin reductase from normal erythrocytes that was not detected in the erythrocytes of an Eskimo with hereditary methemoglobinemia (4). The purified preparation, using 2,6-dichlorobenzene indophenol as electron acceptor, had with NADPH only about 1.5% of the activity with NADH. Hegesh and Avron (20) purified an enzyme

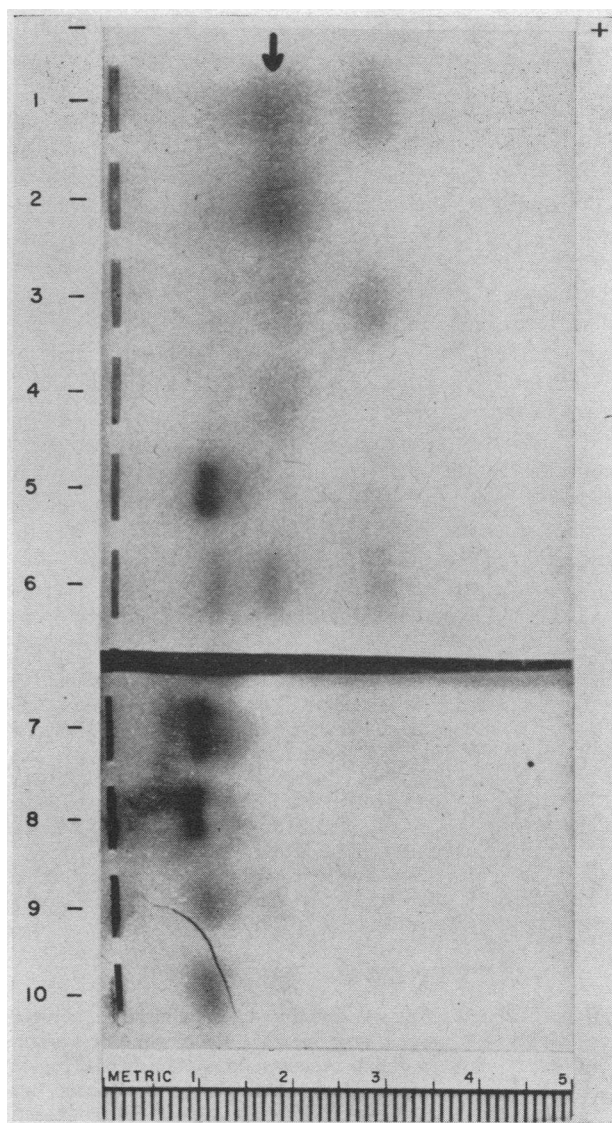

FIGURE 3 NADPH- and NADH-methemoglobin reductase. Starch gel electrophoresis, pH 9.3. Slots 1-6, stained with NADPH; slots 7-10 stained with NADH; slots 1-4, 9, and 10, whole hemolysates; slots 5-8, partially purified enzyme extracts; slots 1, 3, 6, 7, and 10, normal control; slots 2, 4, 5, 8, and 9, from erythrocytes with NADPH-methemoglobin reductase deficiency. Arrow indicates position of hemoglobin A in whole hemolysates.

from human erythrocytes that catalyzed the reduction of methemoglobin by NADH in the presence of ferrocyanide. This enzyme was free of NADPH-methemoglobin reductase activity, although it had some activity with NADPH when other electron acceptors were employed. On the other hand, Kajita, Kerwar, and Huennekens (21) purified three pyridine nucleotide-dependent methemoglobin reductases from human erythrocytes. Each enzyme exhibited both NADH- and NADPH-methemoglo-

bin reductase activities with a constant ratio of about 4:1, but methylene blue was always present in the assay system. The electrophoretic mobility of the bands with NADPH-methemoglobin reductase activity has been shown to be quite distinct from the mobility of the band with NADH-methemoglobin reductase activity (Fig. 3) (8). Both bands with NADPH-methemoglobin reductase activity were absent from the hemolysate of the erythrocytes of the patient with NADPH-methemoglobin reductase deficiency, while the NADH-methemoglobin reductase activity and electrophoretic band were normal. This patient did not have methemoglobinemia, and the ability of his erythrocytes to reduce methemoglobin *in vitro* in the absence of added methylene blue was normal (17). These observations, therefore, would be most consistent with the thesis that a NADH-methemoglobin reductase, distinct from any NADPH-methemoglobin reductase, was the major system responsible for the reduction of methemoglobin in human erythrocytes.

ACKNOWLEDGMENTS

We are deeply indebted to the following individuals for their cooperation in obtaining blood samples from the patients: Doctors Stephen A. Feig (Boston Slow and Boston Fast), Ernest Beutler (Duarte and California), Robert M. Webster (Princeton), Joel M. Schwartz and Frank W. DiPillo (two Puerto Rico patients), L. Juden Reed (Boston Fast, family B), Frank W. DiPillo (Boston Fast, family D), and Mr. Martin D. Sass (NADPH-methemoglobin reductase deficient).

The laboratory investigations were supported by U. S. Public Health Service Grant AM-13698 and the clinical investigations by Grant PO 2 AM-13430.

ADDENDUM

After this manuscript was submitted for publication, a report describing one common and five rare electrophoretic variants of NADH-methemoglobin reductase was published (Hopkinson, D. A., G. Corney, P. J. L. Cook, E. B. Robson, and H. Harris. 1970. Genetically determined electrophoretic variants of human red cell NADH diaphorase. *Ann. Hum. Genet.* 34: 1). The authors noted that the frequency of rare variants was about one in a hundred in a European, Indian, and Negro population sample of 2620 individuals.

Dr. Stephen A. Feig (personal communication) has recently observed that the single band with NADH-methemoglobin reductase activity in the erythrocytes of his patient, designated Boston Fast, may actually be composed of two separate bands with similar, but not identical, mobilities.

REFERENCES

1. Hsieh, H. S., and E. R. Jaffé. 1969. Enzyme variants of DPNH-methemoglobin reductase in hereditary methemoglobinemia. *Blood*. 34: 859. (Abstr.)
2. Jaffé, E. R. 1966. Hereditary methemoglobinemias associated with abnormalities in the metabolism of erythrocytes. *Amer. J. Med.* 41: 786.
3. Scott, E. M., and I. V. Griffith. 1959. The enzymic defect of hereditary methemoglobinemia: diaphorase. *Biochim. Biophys. Acta.* 34: 584.

4. Scott, E. M. 1962. Purification of diphosphopyridine nucleotide diaphorase from methemoglobinemic erythrocytes. *Biochem. Biophys. Res. Commun.* 9: 59.
5. Scott, E. M. 1969. A comparison of two methods of determining DPNH-methemoglobin reductase. *Clin. Chim. Acta.* 23: 495.
6. West, C. A., B. D. Gomperts, E. R. Huehns, I. Kessel, and J. R. Ashby. 1967. Demonstration of an enzyme variant in a case of congenital methaemoglobinaemia. *Brit. Med. J.* 4: 212.
7. Brewer, G. J., J. W. Eaton, C. S. Knutsen, and C. C. Beck. 1967. A starch-gel electrophoretic method for the study of diaphorase isozymes and preliminary results with sheep and human erythrocytes. *Biochem. Biophys. Res. Commun.* 29: 198.
8. Kaplan, J.-C., and E. Beutler. 1967. Electrophoresis of red cell NADH- and NADPH-diaphorases in normal subjects and patients with congenital methemoglobinemia. *Biochem. Biophys. Res. Commun.* 29: 605.
9. Bloom, G. E., and H. S. Zarkowsky. 1969. Heterogeneity of the enzymatic defect in congenital methemoglobinemia. *N. Engl. J. Med.* 281: 919.
10. Detter, J. C., J. E. Anderson, and E. R. Giblett. 1970. NADH diaphorase: an inherited variant associated with normal methemoglobin reduction. *Amer. J. Hum. Genet.* 22: 100.
11. Evelyn, K. A., and H. T. Malloy. 1938. Microdetermination of oxyhemoglobin, methemoglobin, and sulfhemoglobin in a single sample of blood. *J. Biol. Chem.* 126: 655.
12. Jaffé, E. R. 1969. DPNH-methemoglobin reductase (diaphorase). In *Biochemical Methods in Red Cell Genetics*. J. J. Yunis, editor. Academic Press, Inc., New York. 231.
13. Hegesh, E., N. Calmanovici, and M. Avron. 1968. New method for determining ferrihemoglobin reductase (NADH-methemoglobin reductase) in erythrocytes. *J. Lab. Clin. Med.* 72: 339.
14. Hennessey, M. A., A. M. Waltersdorff, F. M. Huennekens, and B. W. Gabrio. 1962. Erythrocyte metabolism. VI. Separation of erythrocyte enzymes from hemoglobin. *J. Clin. Invest.* 41: 1257.
15. Keitt, A. S., T. W. Smith, and J. H. Jandl. 1966. Red-cell "pseudomosaicism" in congenital methemoglobinemia. *N. Engl. J. Med.* 275: 3.
16. Jaffé, E. R., G. Neumann, H. Rothberg, F. T. Wilson, R. M. Webster, and J. A. Wolff. 1966. Hereditary methemoglobinemia with and without mental retardation. A study of three families. *Amer. J. Med.* 41: 42.
17. Sass, M. D., C. J. Caruso, and M. Farhangi. 1967. TPNH-methemoglobin reductase deficiency: a new red-cell enzyme defect. *J. Lab. Clin. Med.* 70: 760.
18. Schwartz, J. M., P. Pares, J. M. Ross, K. Fagelman, F. W. DiPillo, and P. Rizek. 1970. A Puerto Rican variant of NADH methemoglobin reductase in hereditary methemoglobinemia. *Clin. Res.* 18: 396. (Abstr.)
19. Scott, E. M., and J. C. McGraw. 1962. Purification and properties of diphosphopyridine nucleotide diaphorase of human erythrocytes. *J. Biol. Chem.* 237: 249.
20. Hegesh, E., and M. Avron. 1967. The enzymatic reduction of ferrihemoglobin. II. Purification of a ferrihemoglobin reductase from human erythrocytes. *Biochim. Biophys. Acta.* 146: 397.
21. Kajita, A., G. K. Kerwar, and F. M. Huennekens. 1969. Multiple forms of methemoglobin reductase. *Arch. Biochem. Biophys.* 130: 662.